

The Institute of
Acoustics Diploma results
Page 12

NEW IOA report writing and
evaluation course launches
Page 30

Instrumentation Corner:
Will we ever see calibratable
MEMS type chip mics capable of
replacing half inch mics?
Page 46

Technical:
Development of a new
ISO Technical Specification
on non-acoustic factors to
improve the interpretation of
socio-acoustic surveys
Page 54

ACOUSTICS BULLETIN

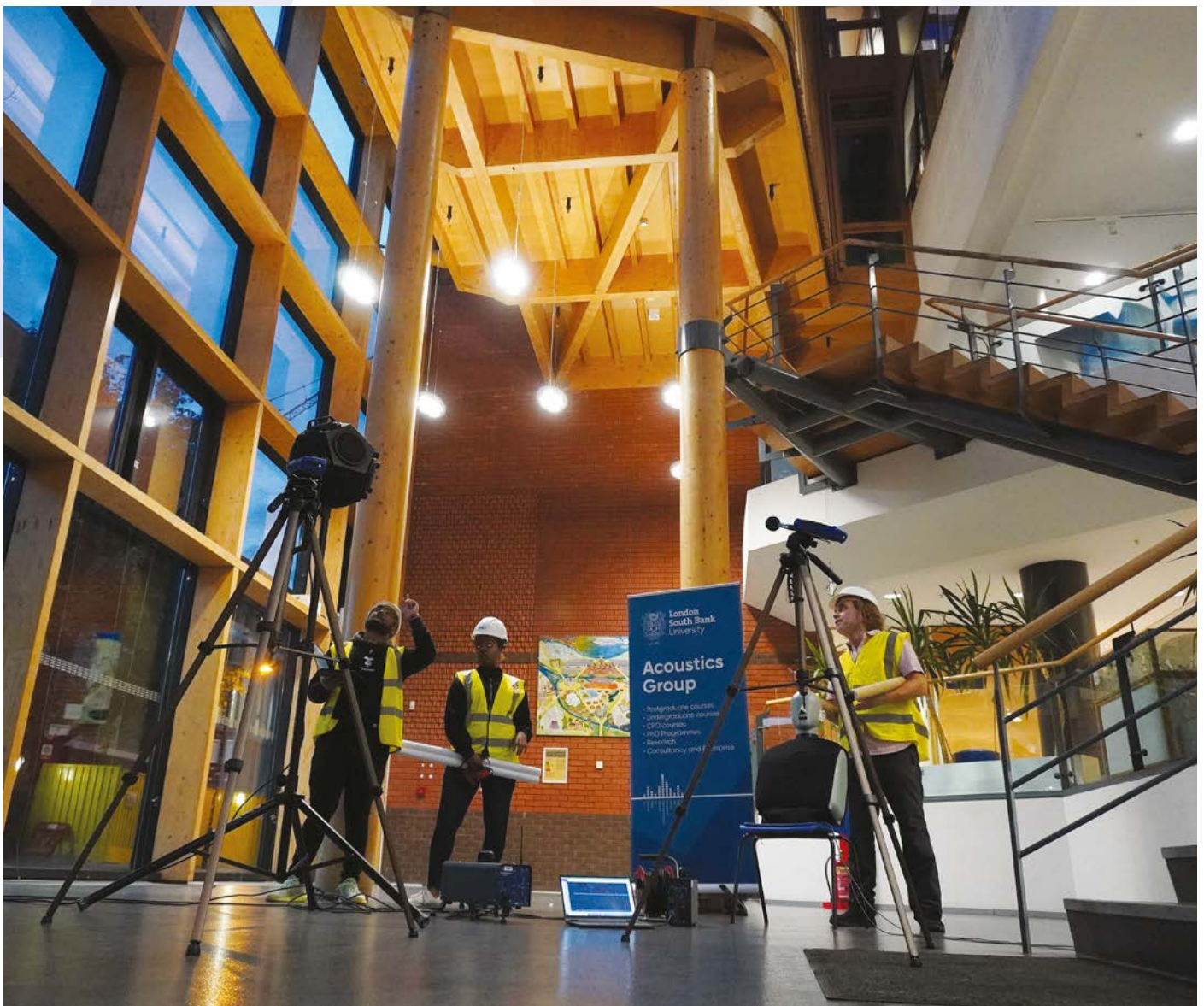

NoiseMap five

Mapping the way to a quieter future...

... for all types of environmental noise

- *Standard prediction methods*
- *Built-in enhancements*
- *Models of any realistic size*
- *Complete all-in-one solution*
- *Contour & individual results stored in database*
- *Compare and combine results*
- *Built-in context-sensitive help*
- *On-line technical support*
- *Printed and video support*



A rail construction site in London analysed by NoiseMap

Click on bullet points to see more, or visit our website:

www.noisemap.com

email: robertompsett@noisemap.com

tel: **+44 20 3355 9734**



Your partners for noise, vibration and air quality systems, sensors and software.

Our customers benefit from market leading support, including onsite visits and custom training programmes, all from a friendly and professional team. We make sure you always feel confident with your equipment.

Be the best
by working **with the best**

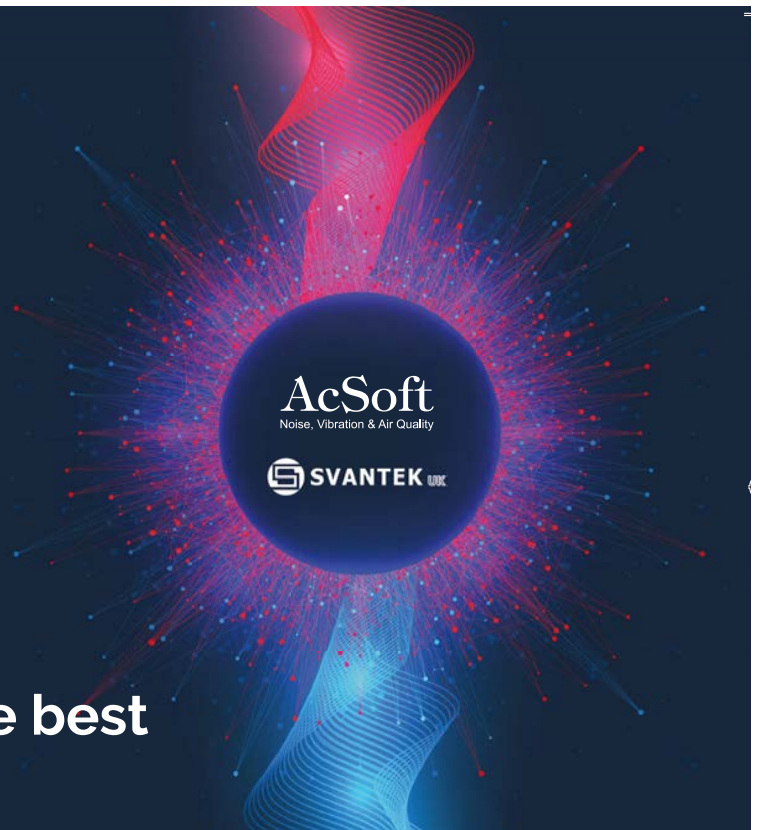

Contacts

Publisher

Juliet Loiselle

Contributions, letters and information on new products to:

Nicky Rogers

Email:

nicky@warnersgroup.co.uk

Tel: 01778 391128

Advertising:

Dennis Baylis MIOA

Email: dennis.baylis@ioa.org.uk

Tel: 00 33 (0)5 62 70 99 25

Published and produced by:

The Institute of Acoustics
Silbury Court,
406 Silbury Boulevard,
Milton Keynes,
Buckinghamshire MK9 2AF
Tel: 0300 999 9675

Edited, designed and printed by:

Warners Group Publications
The Maltings
West Street
Bourne
Lincs
PE10 9PH



Views expressed in Acoustics Bulletin are not necessarily the official view of the Institute, nor do individual contributions reflect the opinions of the Editor. While every care has been taken in the preparation of this journal, the publishers cannot be held responsible for the accuracy of the information herein, or any consequence arising from them. Multiple copying of the contents or parts thereof without permission is in breach of copyright.

Permission is usually given upon written application to the Institute to copy illustrations or short extracts from the text or individual contributions, provided that the sources (and where appropriate the copyright) are acknowledged.

The Institute of Acoustics does not necessarily endorse the products or the claims made by the advertisers in the Acoustics Bulletin or on literature inserted therein.

All rights reserved: ISSN 0308-437X

Annual Subscription (six issues) £140.00
Single copy £24.00

©2022 The Institute of Acoustics

ACOUSTICS BULLETIN

Acoustics Bulletin Volume 48 No 1 January/February 2022

Institute affairs

- 5 President's letter
- 6 Engineering Division
- 10 The IOA five-year strategy
- 12 The IOA Diploma results
- 24 New members
- 30 New IOA report writing and evaluation course
- 32 Peter Barnett Memorial Award 2020/21 citation – Wolfgang Klippel
- 33 Award for Services to the Institute of Acoustics citation – Robin Cross
- 38 Early Careers Group report
- 42 IOA response to Government policies
- 64 Specialist Groups reports
- 65 Inter-noise 2022 Profession, Training and Outreach session

Features

- 26 Acoustic excellence celebrated at ANC awards
- 28 John Connell award winners
- 44 The IOA video Acoustics Bulletin, episode 2 review
- 62 Acoustics in action photoshoot by London South Bank University
- 69 Book review of 'Acoustics in Architectural Design' by Raf Orlowski

Technical

- 54 Development of a new ISO Technical Specification on non-acoustic factors to improve the interpretation of socio-acoustic surveys

Regular

- 25 2022 events
- 40 STEM – virtual work experience for 1,000 students
- 46 Instrumentation Corner: Will we ever see calibratable MEMS type chip mics capable of replacing half inch mics?
- 66 News
- 68 Industry updates
- 70 Institute diary

Our cover image is of students at London South Bank University. As part of the IOA initiative to own a large and diverse stock of images for its media communications and promotional purposes, LSBU kindly donated 865 photos to contribute to that stock. See page 62.



Technical articles review procedure

All technical contributions are reviewed by an expert identified by publications committee. This review picks up key points that may need clarifying before publication, and is not an in-depth peer review.

The Institute of Acoustics is the UK's professional body for those working in acoustics, noise and vibration. It was formed in 1974 from the amalgamation of the Acoustics Group of the Institute of Physics and the British Acoustical Society. The Institute of Acoustics is a nominated body of the Engineering Council, offering registration at Chartered and Incorporated Engineer levels.

The Institute has over 3000 members working in a diverse range of research, educational, governmental and industrial organisations. This multidisciplinary culture provides a productive environment for cross-fertilisation of ideas and initiatives. The range of interests of members within the world of acoustics is equally wide, embracing such aspects as aerodynamics, architectural acoustics, building acoustics, electroacoustic, engineering dynamics, noise and vibration, hearing, speech, physical acoustics, underwater acoustics, together with a variety of environmental aspects. The Institute is a Registered Charity no. 267026

Institute of
Acoustics

Cloud-based noise monitoring with nothing but silver linings only from Cirrus Research

Get instant access to your noise measurement data wherever you are and whenever you need it, and stay in control of your noise impacts with real-time alerts from Quantum Outdoor.

A year's subscription included with every Quantum purchased.

Discover the silver linings:
bit.ly/QuantumOutdoor

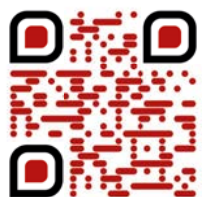

Cirrus
Research plc

Dear Member

I had the enormous pleasure of attending, in person, our Reproduced Sound conference in Bristol last November. One of the privileges of being President is being tasked with presenting Institute awards. At this event, I presented the Peter Barnett Memorial award to Professor Wolfgang Klippel and the award for Distinguished Services to the Institute to Robin Cross. Both very worthy recipients. (See reports on pages 32 and 33).

The papers presented at the conference were as you might expect, including:

- 'How can modern digital to analogue converters achieve 32 bit precision'
- and
- 'Multiphysics simulation of a low frequency horn loudspeaker'.

Equality, diversity and inclusivity

The final presentation at the end of the first day, was entitled: 'Diversity – you can't be what you can't see.'

It comprised a fascinating discussion led by Mark Bailey and supported, online, by Susan Witterick, who is a member of the Institute's Equality, Diversity and Inclusivity (EDI) Working Group.

This is a hugely important and yet challenging topic. There are many considerations concerning equality, diversity and inclusivity and one of the activities of the EDI Working Group is to gather data about our membership to help inform our future decision-making. That is why there are questions on your membership renewal form regarding such matters. Please answer them as fully as you can so that the Working Group can have the best possible data to use.

But there are other inclusivity issues to consider as well. If you have not done so, please may I urge you to read the item in the November/December 2020 issue of Acoustics Bulletin, which introduced readers to some of the EDI Working Group membership. Their pen-pictures touched on a range of issues including the working environment and the timing of Institute activities. These are all factors that can inadvertently work against an individual being able to give of their best and thrive in our profession. As you will also see, not every challenge faced by an individual is obviously visible.

In addressing EDI issues over the coming months and years, we will make mistakes. We will be accused of tokensim. We will be accused of simply making gestures rather than addressing the real issues. But conversely, we can only work with what we have, and we are willing to learn. And, as part of that learning process, the EDI Working Group, the President-Elect and I, amongst others, will be undertaking training in the early part of this year.

Perhaps, then, the immediate challenge for all of us is to make sure that the profession is clearly open and welcoming to all and to challenge ourselves to identify



and understand the obstacles that may unreasonably hinder our members from achieving their full potential as acousticians.

Inter-noise 2022

As you know, we are hosting this event in Glasgow on 21 to 24 August 2022. The call for abstracts opened on 1 December 2021 and the website is up and running: <https://internoise2022.org/>

Our immediate Past-President, Barry Gibbs, is Congress President and says: *"Inter-noise 2022 is a unique opportunity for professionals, working in the field of noise control, acoustics, and vibration, to come together and exchange ideas about their work in an environment conducive to paper presentations and discussions, and informal networking and with many exhibitors in attendance. More than one hundred technical sessions are planned, covering a wide range of issues facing the industry, the research community and the community at large."*

This will only be the second time in the Institute's history that we have hosted Inter-noise. I therefore, urge all members to use this opportunity to come to Glasgow, attend Inter-noise and present a paper. The closing date for the submission of Abstracts is 4 February 2022.

In the meantime, stay safe

Stephen Turner

Engineering Division



The IOA Engineering Division will support you through the process to help you become one of almost 240,000 registrants that hold international professional recognition.

By Blane Judd BEng FCGI CEng FIET FCIBSE, Engineering Manager

Covid variants mean we still are not back to normal office occupancy, but the team are still managing to operate efficiently despite the challenges of hybrid working. The interviews we held in October 2021 went very well and you can read about one of the candidates who was successful and sent in his thoughts and a picture on page 8. Candidates are provided with guidance material when they first apply, and we are always ready to comment on the content of their professional review report prior to them submitting the final draft.

We will now be conducting interviews using the Engineering Council UK SPEC version 4 which is available from their website here: <https://www.engc.org.uk/ukspec>

Emma Lilliman is doing a great job in managing the process remotely as was demonstrated recently when an internal audit was conducted on the process and found no non-conformities.

We are working hard to keep response times down to a minimum while working remotely, so please bear with us.

Neil Ferguson continues to help us with academic equivalence support for those candidates who do not have recognised qualifications. You can check for yourself if your qualifications meet the required specification by visiting the Engineering Council website <http://www.engc.org.uk/courses>. But please don't panic if your specific qualification is not listed, as we can still help you through the process using individual assessment (see later in this article).

We continue to work closely with our Engineering Council Liaison Officer, Malcom Carr-West from the Institute of Agricultural Engineers, who has attended our Engineering Committee meetings but as yet has not sat in on an interview, so yours could be the first!

Our next round of interviews will be in April 2022 and, as usual, we have candidates working towards interview

dates. We hold a number of interview events through the year, depending on the number of candidates we have coming forward for registration. If you are interested in taking the next step to becoming a professionally registered engineer, email us on acousticsengineering@ioa.org.uk sending a copy of your CV and copies of certificates and transcripts of your qualifications. It is important that we have all of your further and higher education certificates, not just your highest attainment.

There are two routes to registration:

The **recognised qualification** route, if you have achieved the required learning outcomes through recognised qualifications in acoustics. Qualifications which provide the required level of knowledge and understanding are for IEng and accredited Bachelor's degree and for CEng an accredited integrated Master's degree or a combination of accredited Bachelor's and Master's degrees (see table below).

Recognised Qualifications

Incorporated Engineer (IEng), one of the following:	Chartered Engineer (CEng), one of the following:
An accredited Bachelor's or honours degree in engineering or technology	An accredited Bachelor's degree with honours in engineering or technology, plus either an appropriate Master's degree or engineering doctorate accredited by a Licensee, or appropriate further learning to Master's level*
An accredited Higher National Certificate (HNC) or Higher National Diploma (HND) in engineering or technology started before September 1999	An accredited integrated MEng degree
An HNC or HND started after September 1999 (but before September 2010 in the case of the HNC) or a Foundation Degree in engineering or technology, plus appropriate further learning to degree level	An accredited Bachelor's degree with honours in engineering or technology started before September 1999
A National Vocational Qualification (NVQ) or Scottish Vocational Qualification (SVQ) at level 4 that has been approved by a Licensee, plus appropriate further learning to degree level*	Equivalent qualifications or apprenticeships accredited or approved by a Licensee, or at an equivalent level in a relevant national or international qualifications framework†
Equivalent qualifications or apprenticeships accredited or approved by a Licensee, or at an equivalent level in a relevant national or international qualifications framework†	

* See: www.engc.org.uk/ukspec4th for qualification levels and HE reference points. † For example, UNESCO's International Standard Classification of Education (ISCED) framework.



The **individual assessment** route, for applicants who do not have the recognised qualifications and who will have an individual assessment of their qualifications and any other relevant learning, such as formal academic programmes, in-employment training, experiential learning and self-directed learning. In many instances, it is likely to be a combination of some or all these options.

Remember, we are here to help you get through the process and advice and support is offered to every candidate personally.

Academic requirements

For individual assessment, the IOA accepts several courses in relevant subjects such as audio technology, from certain academic centres,

as being equivalent to accredited courses for the purposes of EC registration, without the need for further assessment.

The Institute recognises the IOA Diploma course and the several Master's courses linked to it as providing evidence if you are looking to gain CEng registration. You could also offer a PhD qualification, depending upon the content of the associated taught element. We can also offer support for registration via a 'technical report' route, if you do not have the relevant qualifications to help you demonstrate you are working as a professional engineer in acoustics. If you need to follow the technical route, we will discuss this with you before you embark on that process.

Election process

The election process is overseen by the IOA's Engineering Division Committee, which is made up of volunteers from the membership, to whom we are extremely grateful. They represent the 300 or so members holding EC registration and provide the essential peer review process that affirms that you are at the appropriate level for recognition as an Engineering Council Registered Professional Engineer. ©

The opportunity is there, and we are ready to support you through it, so that you can become one of almost 225,000 registrants that hold International professional recognition.

Engineering Council

successful candidate



The Engineering Council is the UK regulatory body for the engineering profession. It holds the international registers of Engineering Technicians (EngTech), Incorporated Engineers (IEng), Chartered Engineers (CEng) and Information and Communications Technology Technicians (ICTTech).

It also sets and maintains the internationally recognised standards of professional competence and ethics that govern the award and retention of these titles.

This ensures that employers, government and wider society can have confidence in the knowledge, experience and commitment of professionally registered engineers and technicians.

The IOA is pleased to announce that John Edhouse has attained the standard required for admission to the national register at Chartered Engineer level.

John Edhouse CEng

John always enjoyed music and science throughout his schooling. He graduated with a masters in physics from the University of Southampton in 2010 and after that, worked at 24Acoustics in Hampshire from then until 2017 on a diverse range of projects in both environmental and building acoustics across the UK.

He moved to Mott MacDonald in 2018 and is still there, focusing on environmental acoustics by working on a diverse range of projects including power and energy, highways, rail, residential, minerals and waste within the UK and abroad.

Reflecting on his Chartered Engineer registration, John said: "Attaining CEng is a significant milestone in my career and it has been a challenging but also rewarding process.

"The process provided an opportunity to reflect and review on personal achievements in my career to date and refocus on future goals.

"My academic qualification allowed me to apply via the individual route, which required preparation of a technical review report – the pandemic forced a few delays in preparing my application, and I am grateful to support from the IOA and colleagues in reviewing documents and preparing for the interview." 



ONE METER, MULTIPLE APPLICATIONS THE NOR-145



BUILDING ACOUSTICS



NOISE NUISANCE



MONITORING STATION

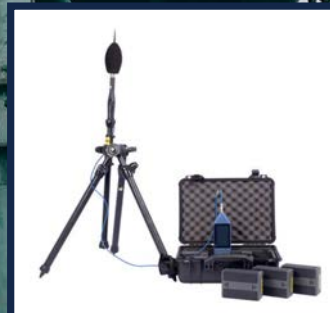

OUTDOOR MONITORING

Norsonic

CONTACT US TODAY

t: 01371 871030 | e: hotline@campbell-associates.co.uk | w: campbell-associates.co.uk



CAMPBELL ASSOCIATES
SOUND, VIBRATION & AIR SOLUTIONS

The Institute of Acoustics Strategy

In February 2019, around 70 members of the Institute gathered in Milton Keynes to attend a workshop with the aim of refreshing our five-year strategy plan. Stephen Turner, IOA President, reports on a follow-up meeting held in September 2021.

At the meeting in February 2019, we identified six strategic aims: These were:

1. Influencing the acoustics agenda;
2. Developing tomorrow's professionals;
3. Maintaining professional standards and members' skills;
4. Delivering excellent service to members;
5. Commitment to public benefit; and
6. To be a catalyst for acoustics research.

Each aim was accompanied by several objectives and associated tasks.

Following the impact of the pandemic, and with us all adjusting to the new normal, Council felt that the time was right to revisit the strategy and identify any changes we should make.

Consequently, in September 2021, members of the IOA Council plus the chairs of the standing committees attended a hybrid meeting to discuss the strategy. We had about half the attendees in Milton Keynes and the rest online.

Reviewing and resetting

As in February 2019, the meeting was facilitated by Steve Potts of SHM. The objective of the session was to set the basis of a new strategic plan for the next two to three years by reviewing and resetting the strategic aims, and then identifying the key tasks we need to achieve to deliver those aims.

Some of the main points which arose from the opening discussion included:

- Due to the pandemic, people have been spending more time in front of their computers.

Responding to this change in a timely fashion has been challenging, but the IOA has adapted well by introducing digital and hybrid offerings. This has resulted in some of our members actually feeling more connected to us than ever before.

- More people are taking an interest in science and the environment, which is pushing noise and noise pollution higher up in people's agendas. Health and wellbeing are more important to people and we should look to capitalise on this development.
- There is more we can do to engage younger people, provide more education opportunities, and make the entry into the world of acoustics easier.
- One of our biggest successes is our volunteer strength. But we

need to do more to raise the participation levels in volunteering roles by making it easier to become involved and help the IOA.

- Research is the vital backbone of our organisation. Our ability to coordinate and expand access to the research carried out by other organisations in related fields needs to be improved.
- A lot of our successes and failures come down to energy and passion. The projects that have the most energy tend to become successful. We must be aware of this and address it by diversifying our enthusiasm; and
- There is more we can do to raise the importance of acoustics in the decisions made within politics. Responding to consultations and being more central to decisions is key.

Proposed revisions to strategic aims

2019 Aims	Proposed 2021 Aims
Influencing the acoustics agenda	Influencing to improve acoustics outcomes
Developing tomorrow's professionals	Developing tomorrow's professionals
Maintaining professional standards and members' skills	Improving professional competency and enabling the development of members' skills
Delivering excellent service to members	Delivering excellent service to members
Commitment to public benefit	Commitment to provide public benefit to promote acoustics
To be a catalyst for acoustics research	To be a catalyst for acoustics research

The attendees were divided into six groups, each one covering one of the previous strategic aims. As a result of the group discussions, there were proposed changes to some of the original aims, whilst others remained the same (see box above).

Although some progress was made at the meeting on identifying the supporting objectives, more work needs to be done and it is intended that this will occur during 2022. ©

In the meantime, if any member would like to contribute to the IOA Strategy, please contact HQ at ioa@ioa.org.uk

Acoustic Panels

Soundsorba manufacture and supply a wide range of acoustic panels for reducing sound in buildings.

www.soundsorba.com

Wallsorba™



- Wide range of modern vibrant colours
- Soft fabric facings
- Custom sizes can be manufactured
- Class A performance

Woodsorba™

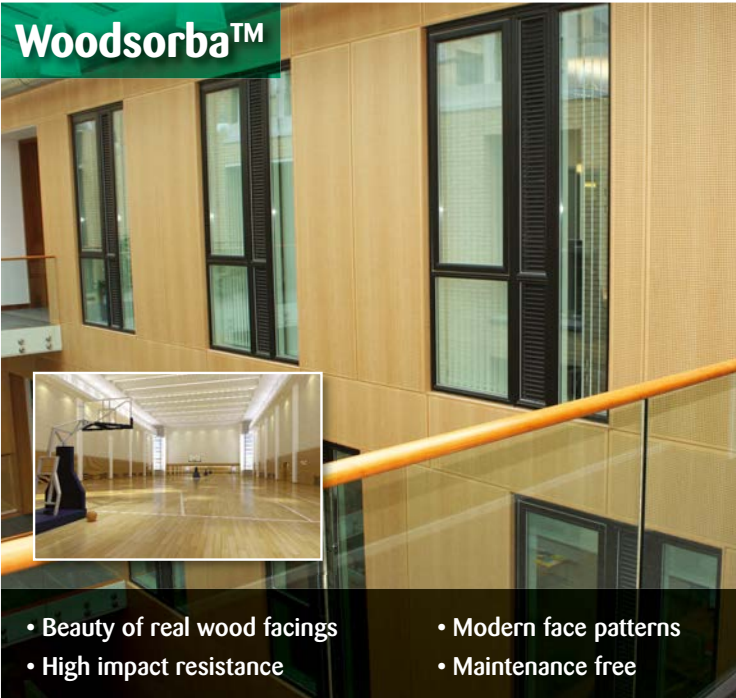

- Beauty of real wood facings
- Modern face patterns
- High impact resistance
- Maintenance free

Wavesorba™



- Futuristic shape
- Soothing wave pattern
- Lightweight
- High acoustic performance

Cloundsorba™



- Wider range of different shapes available
- High acoustic rating
- Suitable for a wide range of building interiors

Soundsorba's highly skilled and experienced acoustic engineers will be pleased to help with any application of our acoustic products for your project.

Please contact us by calling **01494 536888** or emailing info@soundsorba.com for any questions you may have.

SOUNDSORBA®
ACOUSTIC PRODUCTS

TEL: +44 (0)1494 536888
FAX: +44 (0)1494 536818
EMAIL: info@soundsorba.com

SOUNDSORBA LIMITED, 27-29
DESBOROUGH STREET, HIGH
WYCOMBE, BUCKS HP11 2LZ, UK

The Institute of Acoustics Diploma results 2020

By Professor K Attenborough, HonFIOA (IOA Education Manager)

The 2020/2021 presentation of the IOA Diploma in Acoustics and Noise Control was centre-based at four institutions (Leeds Beckett University, London South Bank University, Southampton Solent University and University of Derby) and delivered in its tutored distance learning version through four Centres (Bristol, Edinburgh Napier University, Milton Keynes and Trinity College Dublin).

The Covid-19 pandemic made it impossible again to hold written examinations at centres in 2021. Consequently, the examinations were downloaded 'at home' and written answers scanned and submitted online within four days of the release of the papers. This made the examinations essentially 'open book' with the result that fewer candidates have failed than has been typical.

The continuing pandemic caused some candidates to change their project topics and methods and 18 candidates deferred until 2022.

In 2021, there were 75 candidates (including six resits) for the General Principles of Acoustics (GPA) module examination, eight (including one resit) for Regulation and Assessment of Noise (RAN), 34 (including one resit) for Noise and Vibration Control Engineering (NVCE), 62 (including

three resits) for Building Acoustics (BA) and 38 (including two resits) for Environmental Noise Measurement, Prediction and Control (EN).

Of the 86 candidates registered for the Project module, 24 are listed as having failed the project in the table of results, but, as mentioned earlier, 18 deferred as a result of the pandemic.

As in previous years, a merit threshold of 70% was applied to the written GPA paper and the conflated GPA mark. The examination scripts of candidates satisfying the conflated mark threshold but gaining between 68% and 72% on the written paper were examined at moderation, re-marked where appropriate and judged individually as 'pass' or 'merit'. However, even if these criteria were satisfied, a merit was not awarded if a coursework assignment mark was carried over from a previous year.

Criteria based on the means and standard deviations from the previous nine years were used to decide whether to moderate examination marks for the specialist modules. The EN assignment turned out to be much too long, so the mean mark achieved for the EN assignment was significantly less than the mean marks obtained for the other specialist module

assignments. Account was taken of this at moderation. To obtain a merit grade on the specialist modules, candidates were required to have conflated mark and written examination marks of at least 70%. No merit was awarded if it depended on a deferred score.

GPA coursework assignments were about:

1. outdoor entertainment noise; and
 2. the rather topical topic of the acoustical requirements of working at home!
- They resulted in mean marks of 65% and 71% respectively.

The specialist module coursework topics this year included the acoustical challenges of open plan offices (NVCE), cinema design (BA), non-acoustic factors and public participation (RAN) and measurement, calculation and assessment of wind farm and other industrial noise (EN).

For the first time this year the NVCE coursework asked candidates to produce and record a video presentation. This has proved sufficiently successful that it is to be repeated, extended to the project and relevant transferable skills listed in the diploma learning outcomes. [P14](#)



SVANTEK

01234 639551

www.svantek.co.uk

sales@svantek.co.uk



PRECISE. POWERFUL. ACCURATE.

SVANTEK boast one of the best qualified and most innovative teams of design engineers in the market.

Our range of noise and vibration monitors is second to none with both quality and technical excellence being at the core of the company's philosophy.

- Whole body human vibration
- Hand-arm vibration
- Noise at work
- Environmental noise and vibration
- Building acoustics
- Building and ground vibration

The numbers of candidates who gained merits (M), passes (P) or fails (F) in each module are shown for each centre in the following table of results. The 'fails' include those who were absent from the written examinations.

Eight exceptional candidates have obtained five merits. The prize for best overall diploma performance (based on gaining the highest overall marks for GPA, RAN, LABS and merits for the EN and project modules), is to be awarded to Frances Taylor (University of Derby).

Letters offering congratulations on achieving five merits also, have been sent to:

- Gareth Hance (London South Bank University);
- Jonathan Howell (University of Derby);
- Matthew Hunt (University of Derby);
- Seena Sajeev (DL Edinburgh);
- Ahmed Sheriff (DL Milton Keynes);
- Ning Tang (DL Milton Keynes); and
- Alex Champion (DL Milton Keynes). P16



Sound Masking

from aet.gb ltd

Open plan offices benefit from Sound Masking



Cellular offices achieve better speech privacy with Sound Masking

Sound Masking is a cost effective solution to the problem of improving speech privacy in today's modern office environment. Best installed during office fit out but often installed as retrofit, Sound Masking from AET has improved the office environment for many international companies throughout Europe over the last 20 years.

In today's office speech privacy becomes a key aim and open plan offices can suffer from two speech problems:

- Other people's conversations can be an irritating distraction
- Confidential conversations can be almost impossible to conduct

Similar problems also exist in cellular offices. Apart from noise breakthrough via partitions, flanking over, under and around them, other problem areas include light fixtures, air conditioning systems and services trunking. Sound masking compensates for these problems.

An investment in increasing privacy of speech is certainly cost effective, with Sound Masking one of the easiest ways of achieving this aim. Sound Masking systems along with acoustic panels and acoustic door seals are increasingly used to achieve the desired level of privacy by a number of our major clients including:

- Vodafone World HQ
- Procter & Gamble
- Swiss Re
- Mobil Exxon HQ
- Elizabeth Arden
- Barclays Bank
- Freshfields
- KPMG
- PWC
- BP



Sound Masking is now available with a host of extras including:

- PA, either all call or zone by zone call
- Dual level options for audio visual room etc
- Automatic ramping to conserve energy and produce profiled masking
- Fault reporting
- Automated amplifier changeover



www.aet.co.uk

AET.GB Ltd., 82, Basepoint, Andersons Road, Southampton, Hampshire SO14 5FE
Tel: 0044 (0)8453 700 400 sales@aet.co.uk

Sound Masking is also known as sound conditioning or white noise systems



Certificate Number 130222

Special commendation letters for achieving four merits, have been sent to:

- James Gardner (London South Bank University);
- Andrew Hawkins (DL Bristol); and
- Sean Horsman (DL Dublin).

Sean Rocks will be receiving the prize for the best overall diploma performance by an Irish student.

James Oatley has been awarded the 2019-20 ANC Prize for the

project; 'Dynamic Compensation Convolution for MEMS Microphones in Professional Sound Level Meters'.

I am grateful to all examiners and tutors for their cooperation and contributions in this second difficult year. Thanks again to Helen Davies and Caitlin Jesney for their steadfast and excellent contributions during the 2020/2021 presentation year of the diploma. [P18](#)

IOA Diploma Results Chart for 2020/21

Centre Name		GPA	Labs	BA	NVCE	RAN	EN	Project
Distance Learning (Bristol)	Merit	2	2	3	1	0	0	0
	Pass	3	1	1	1	1	1	2
	Fail	0	2	0	1	0	1	3
Distance Learning (Dublin)	Merit	3	2	2	0	0	0	4
	Pass	2	3	2	0	2	2	1
	Fail	1	0	0	2	0	2	4
Distance Learning (Edinburgh)	Merit	2	1	1	0	0	1	1
	Pass	2	2	0	0	2	1	4
	Fail	0	0	0	1	0	1	4
Distance Learning (Milton Keynes)	Merit	5	7	13	7	0	1	4
	Pass	19	16	10	9	0	7	16
	Fail	3	1	2	1	0	2	6
Leeds Beckett University	Merit	4	4	2	0	2	0	0
	Pass	2	1	1	0	0	5	7
	Fail	0	0	0	0	0	0	0
London South Bank University	Merit	2	3	5	7	0	0	4
	Pass	9	8	5	3	0	0	5
	Fail	0	0	1	1	0	0	2
Southampton Solent University	Merit	3	1	0	0	0	0	0
	Pass	3	5	5	2	0	2	4
	Fail	0	0	0	1	0	2	2
University of Derby	Merit	5	4	2	0	1	3	5
	Pass	6	8	7	0	0	8	6
	Fail	1	0	2	0	0	1	2
Totals	Merit	26	24	28	15	3	5	18
	Pass	46	44	31	15	5	26	45
	Fail	5	3	5	7	0	9	23

MAKING YOUR WORLD A QUIETER PLACE

Siderise have over 45 years' experience in designing, developing and manufacturing acoustic and fire insulation solutions for building interiors.

The Siderise FIP high-performance acoustic panel, which is a thin multi-layered board offering exceptional sound transmission performance and has been specifically developed to provide a solution where an internal partition abuts a curtain wall or window mullion.

Due to the 46dB Rw performance at only 31mm thickness, the Siderise FIP high-performance acoustic panel can also be used in many other conditions which demand the combination of a high SRI performance with a minimal thickness.

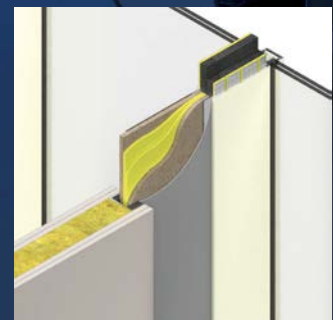
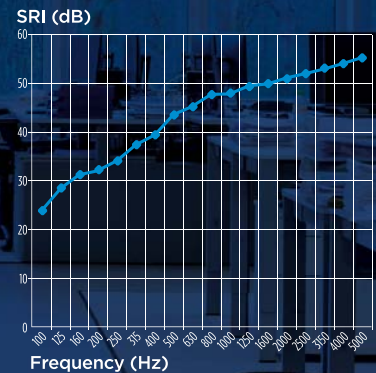

SIDERISE® FIP

Find out more: www.siderise.com/products/interiors

T: +44 (0)1473 827695 F: +44 (0)1473 827179 E: technical.sspl@siderise.com

BY
YOUR
SIDE

Project titles 2020

Distance Learning (Bristol)

- An investigation of the acoustic conditions within the auditorium of a small performing arts centre
- An investigation into using loofah gourd fibres as a sustainable sound absorbent material

Distance Learning (Dublin)

- The impact of electric vehicles on road traffic noise levels in urban areas
- The acoustical conditions of Irish language primary schools in Northern Ireland
- An analysis of auditorium acoustic; The Labour Exchange Building
- Evaluation of wind noise exposure to cyclists using a bespoke in-ear sound level metering system
- Classification of environmental noise sources using machine learning

Distance Learning (Edinburgh)

- Soundscape approach to residential noise impact assessment: potential to deliver improved outcomes
- The significance of significant in industrial noise regulation
- Investigation of vegetation as an environmental noise barrier for trunk road mitigation
- An investigation into impact noise on various surfaces distributed horizontally and vertically in a household
- An investigation into the validity of sound power level estimation methods for power transformers

Distance Learning (Milton Keynes)

- Sound power level of the flow noise (or regenerated sound) of a louvre and louvre attenuation
- Experimental study on improvement of noise control and sound reduction index of the generator room walls

- Field measurement of impact – sound insulation of different floor constructions in Jordan
- Passive noise control of a cooling fan
- Effectiveness of an existing acoustic barrier for traffic noise
- Measurement and survey of acoustics and noise isolation qualities of two recording studios in Cambodia
- Assessment of outdoor noise pollution during post-development construction of a residential tower in Qatar
- Prediction of in-duct HVAC silencer's dynamic insertion losses (DIL) and Comparison of Noise Measurements with design predictions to check its compliance with target noise criteria (NC) levels
- An investigation of HVAC system noise in a community hall
- Critical assessment of speech intelligibility of video conferencing tools to maximise acoustic performance
- Acoustic performance study of moveable partitions vs conventional dry wall partitions
- Impact noise attenuation for electronic drums in lightweight timber framed flats
- Assessing the feasibility of the Norsonic 850 Analyser within the Acoustic Labs at The Building Test Centre
- The comparison of sound absorption coefficient values obtained with the testing performed in a non-standard testing room when compared with reverberation chamber or impedance tube method
- Noise attenuation of a vibrating vessel using an acoustic enclosure – duct parameters study
- Evaluating the suitability of existing guidance for assessing and predicting the impact of peacock noise on the surrounding environment
- Air-borne noise transmission control from generator room to hotel guest room
- Sources of noise and the effect on vocal masking in a home and a theatre
- Acoustic compliance to the WELL and BCO standards for an office
- The acoustic properties of handclaps for reverberation time measurement and comparison to other methods
- Acoustic effects of surgical and N95 masks on speech perception

Leeds Beckett University

- The effects of using an acoustic drum screen to protect hearing in an amateur music group
- Workplace noise assessment of the refuse team at Craven District Council (bin wagon drivers and loaders)
- An investigation into the noise impact of converting all internal combustion engine vehicles into electric on the UK urban environment
- An investigation into the effect the angle of incidence has upon sound propagating through a temperature gradient
- Noise impact of relocating the council's waste/recycling fleet to its Doughty Road facility
- Measurement of airborne sound insulation of the glass consultation room within Hambleton District Council's Civic Centre Reception
- Hand-arm vibration assessment of a handheld powertool and the effects of vibration on the hand-arm system [P20](#)



experts in acoustics for industrial applications

Whether it's reducing dangerous noise to meet **Control of Noise at Work Regulations** or ensuring noise pollution falls within the **Pollution Prevention and Control Regulations**, CMS Danskin Acoustics have the products, knowledge and experience, from offshore platforms to power stations, oil refineries to cement mills.

Damping Sheet

SuperLag

Plant Room
Wall Lining Panels

SuperPhon Hardface

Quietslab Laminate

WB Barrier

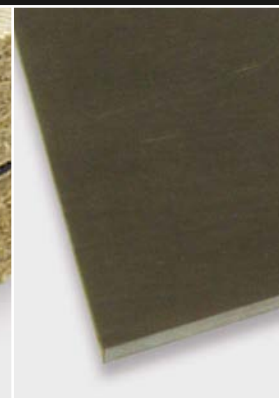
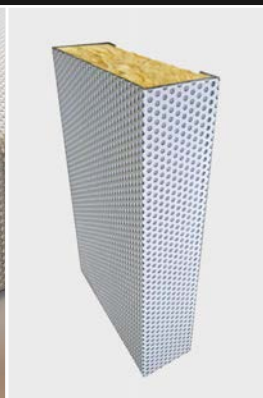
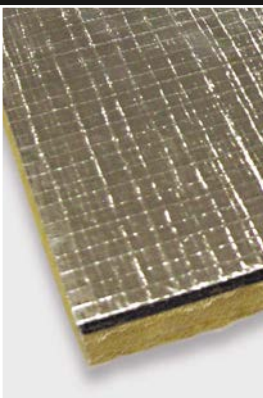
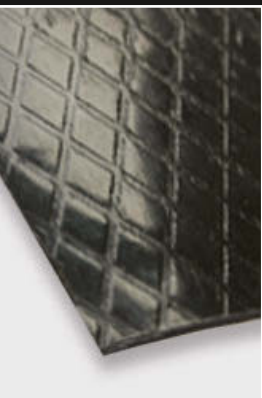

London South Bank University

- Acoustical ecological survey of harbor porpoises in the North Sea
- C-Weighting assessment for environmental low-frequency control at outdoor concerts
- Evaluating the impact of anthropogenic noise on the natural soundscape of Jubilee Country Park
- The acoustical challenges of a change of room purpose
- Acoustic quality and comfort in gymnasiums. A case study of Bob Prowse Health Club, Maidstone, UK
- A tool to identify domestic noise nuisance
- Performance validation of alternate loudspeakers for use as artificial mouth simulators for speech intelligibility measurements
- Road traffic noise and its effect on the residents of Witchford
- Efficacy of cladonia rangiferina as sound absorption material

Southampton Solent University

- Noise attenuation in motorcycle helmets relating to emergency services siren recognition
- A case study into the noise exposure of studio engineers working within rock and metal and the Control of Noise at Work Regulations 2005
- A comparison of the sound exposure level calculations of rail transport noise and the measured equivalent level at the façade of a building in a rural environment
- Sound insulation testing – single figure ratings and the possible variances in outcome due to room modes

University of Derby

- Assessing the accuracy of method 1 of the TRL report 'Converting the UK Traffic Noise Index LA10, 18h to EU Noise Indices for Noise Mapping'

- Effectiveness of variable acoustics in multipurpose halls
- An investigation into BS 4142's façade correction factor
- A case study on acoustics and noise control in urban green spaces in East Park, Kingston Upon Hull
- Tranquillity and low frequency noise in Shipley Country Park, Derbyshire
- An Investigation into the suitability of BS 5228:2009 + A1:2014 for managing the environmental noise impact from pre-construction site investigations utilising window sample drilling rigs
- Distortion perception and its applications in real-world scenarios
- The use of smartphones to evaluate environmental noise: a comparison of smartphone apps with a Type 1 sound level meter
- Validating the TRAPT and utilising it to predict the tranquillity of Victoria Park, Leicester
- Is the rating of impact sound insulation for separating floors in Building Regulations Document E 2003 fit for purpose
- Analysis of noise impact assessments of skate parks

Diploma awarded 2021

Distance Learning Bristol

Croft J
Hawkins A

Distance Learning Dublin

Aiken C
Hamilton A
Horsman S
Mythen C
Rocks S

Distance Learning Edinburgh

Chisholm J
Sajeev S
Sim N
Wager I
Watson E

Distance Learning Milton Keynes

Abdullah K S
Allan N
Alnajjar A
Bergmanis T
Bhatia M
Calma S
Champion A
Dube I
Eden M
Ganatra P
Hendley J
Kim K
Lui N S
Philip T
Sheriff A
Tang N
Tunstall J
Unnikrishnan H
Venkateswaran G
Yang Z
Yap J

Leeds Beckett University

Corry S
Dent A
Hible D
Jenkins T
Poole S
Reed L
Storey J H

London South Bank University

Berman C
Brown C J
Gardner J
Gurney P
Hance G
Hare D
Howe A
James A
Suseela Thankom Mohan L

Southampton Solent University

Carray K J
Mcintosh E C
Nicholson B

University of Derby

Bayne J
Chambers C T
Harrison L
Hollis A
Horwich A
Howell J M
Hunt M
Phillips J
Ranger M
Tatar P
Taylor F J

The Institute of Acoustics certificate results 2021

During the ongoing pandemic in 2021 some centres were still unable to offer the certificate courses, whereas others were able to adapt to the Covid-19 restrictions by limiting numbers. This year saw an increase in the number of centres delivering courses as well as an upturn in the overall number of candidate registrations. CCBAM and CCENM have proved most popular with similar numbers for CCWNRA and CCMOEHAV. Also, as a result of the decision of Southampton Solent University to cease offering its acoustics courses, a new centre (KP Acoustics Research Labs) formerly Positive Acoustics, has been offering CCBAM and CCENM in Southampton.

List of successful candidates

Certificate:
Building Acoustics Measurements
Exam date: 29 January 2021

Positive Acoustics

Etheridge D
Gajjar S
Grove T
Hallam G
Nunn J
Pimlett M

Exam date: 30 April 2021

Babariya N
Branagham C
Britton T
Brown S
Bucco Santiago F
Carroll P
Kershaw P
May M
Mnych S
Murphy C
Mustarde A
Samuels T
Singh V
Toner S
Waidson D

Certificate:
Environmental Noise Measurement
Exam date: 14 May 2021

Colchester Institute

Baylis A
Bucco Santiago F
Duff-Cole R
McCarthy K
Roberts S
Scotney L

Positive Acoustics

Babariya N
Brown S
Donnelly M
Murphy C
Stephens G
Tanner C

Liverpool University

Bradshawe H
Favill G
Jackson R
Jones A
Stout C
Wall A **P22**

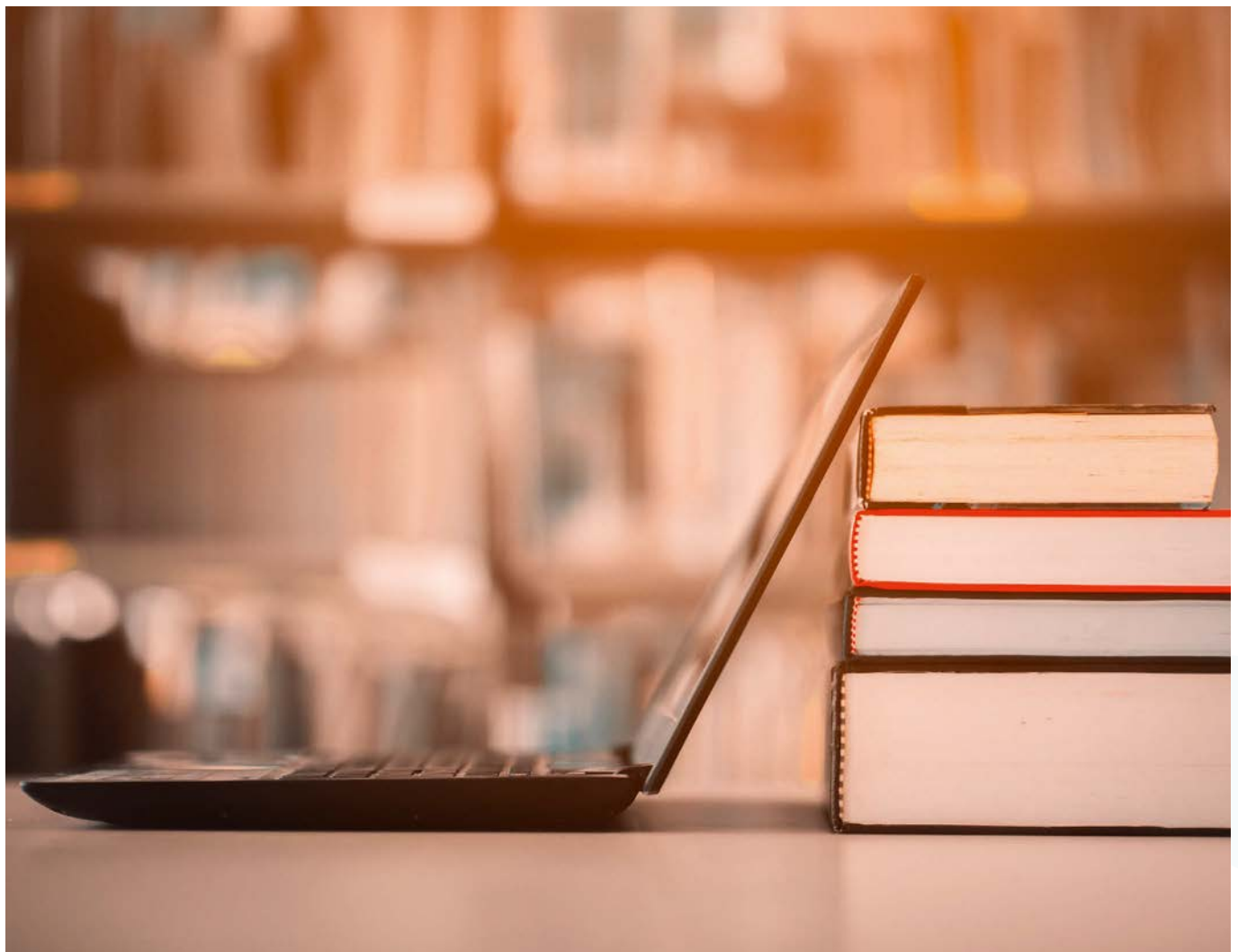

London South Bank University

Banton E
Barnes A
Best W
Callard E
King T
Lane K
Pisarczykowski P
Seath T
Watson R
Weyer M

Shorcontrol

Buckley S
Donovan B
Doyle Cairney K
Ryan L

Certificate:

Building Acoustics Measurements

Exam date: 16 July 2021

KP Acoustic Research Labs

Best M
Booth G
Heggarty D
Housego J
Lumsden M
Macfarlane E
Searle A

Exam date: 10 September 2021

KP Acoustic Research Labs

Ahmadi A
Chambers D
Elliott T
Hayes A
Margovan J
Myerscough N
Nelson J

Certificate:

Management of Occupational Exposure to Hand-arm Vibration

Exam date: 24 September 2021

Institute of Naval Medicine

Clark-Acaster J
McAlwane D
Nickless L
Scanlon D
Wood N
Woodbridge R

Certificate:

Workplace Noise Risk Assessment

Exam date: 1 October 2021

Make UK

McCall S
Nicolaidis C
Walker R

University of Derby

Bingley J
Hussain A
Nixon J
Yip K

Certificate:

Environmental Noise Measurement

Exam date: 8 October 2021

Colchester Institute

Coyle L
Evans H
Hack O
James H
King L
Oliver K

KP Acoustic Research Labs

Charman L
Downs S
Joyner L
Le Page C
Lundberg L
Richards C
Robinson N
Ryan V
Savage-Brookes M
Senyah E-J
Wood K

KP Acoustic Research Labs (Jersey)

Briggs R
Brundell L
Chamberlain C
Cragg R
Humphreys-Foott M
McMahon G
Parsons A
Thomas S

Leeds Beckett University

Atkinson K
Bainbridge S
Convey-McGovern E
Cowell R
Dacre D
Davey L
Dickinson J
Godson H
Hart J
Hunt A
Jarratt H
Johnston A
Linden E
Nicholson T

Liverpool University

AP Geraint B
Caldwell P
Clark N
Fish A
Fisher R
Francis W
Heaton C
Noble C

Shorcontrol

Barry K
Daly U
Gaffney K
Long D
Pawlicki M
Wallace K

Ulster Environmental

Collins J
Leonard L
McAleavey L
McGarrigle E
Reid K

University of Derby

Hatfield D
Hatfield S
Mahmoudi K
Mikinka J
Mrozek K
Salpekar S
Sargent M
Thompson H
Watson C ©

SF Xtra Sound Attenuator

Sounds like a good choice...

Ventilation with noise reduction:

- Attenuates up to 44dB when the vent is open - $D_{n,e,w} (C;Ctr) = 44 (-2;-3)dB$
- Independently tested and verified by BRE and Sound Research Laboratories Ltd
- Available in 2500mm² EA and 5000mm² EA unit sizes
- Standard and special (RAL match) paint finishes
- Can be used on standard Titon slot sizes

 Titon®

TITON.COM/ACOUSTIC



WANT A QUALIFICATION THAT ASSURES YOU OF GOOD JOB PROSPECTS?

Established for more than 40 years, the Institute provides graduates, and those with a proven interest in acoustics, the chance to become a recognised member of a vibrant and active global network with regular UK meetings and CPD.

The Diploma in Acoustics and Noise Control includes the General Principles of Acoustics, Laboratory and Experimental Methods and a Project.

Choose Specialist Modules from:

- Building Acoustics
- Regulation and Assessment of Noise

- Environmental Noise: Measurement, Prediction and Control
- Noise and Vibration Control Engineering

The Diploma is taught in centres across the UK or through distance learning with live tutorials – find out more: www.ioa.org.uk/education-and-training

FOR MORE INFORMATION:

www.ioa.org.uk E: education@ioa.org.uk T: +44 (0)300 999 9675

Institute of Acoustics, Silbury Court, 406 Silbury Boulevard, Milton Keynes MK9 2AF



Approved Membership Applications

The Membership Committee reviewed 75 application forms on 28 October 2021 at the first face to face meeting since lockdown in 2020. 30 applications have recently been approved by the Council following the recommendations of the Membership Committee. The committee saw 33 new candidates joining the IOA, the remaining being members upgrading or being reinstated.

FIOA

Alexandre Krasnic

MIOA

James Beer	Mark Kubis
Joao Carrilho	Laura Mazzeo
Ross Chamberlain	James Morphet
Thomas Citrine	Ciaran Murphy
Stephen Cook	Nick Myerscough
Anthony Coraci	Daniel Newbery
Celia Diaz Brito	Juan Emilio Noriega Linares
Neil Durham	Oliver Packman
Pete Erskine	Lisa Payne
Richard Evans	Jake Schofield
Kirsty Farquharson	Joy Stevens
Sam Geering	Antonio Taddei
Antonia Hawker	Marcus Wiseman
Cameron Heggie	Jessica Wright
Matthew Hopley	

AMIOA

Nicholas Allan	Alexander Dell	Jacopo Lozupone
Carlos Barbera	Sebastain Duran	Ciaran Maloy
Michael Bowie	Aaron Fox	Stephen Moore
Jake Brickley	John Gray	Aaron Moroney
Jay Butler	Crispin Halcrow	Rebecca Romeo Pitone
Jim Candlin	Ross Hammond	Joseph Rutt
Matthew Coll	James Hardacre	James Sharpe
Paul Couper	Thomas Keenan	Ryan van Wensveen
Henry Cox	Gokce Kutsal	

TechIOA

Steven Lambourne	Phoebe Webber
------------------	---------------

Affiliate

Colum Breslin	Nicole Jackson
---------------	----------------

Enhance your career prospects in acoustics

The IOA runs a range of certificated short courses nationwide, assessing competence in the areas shown. The courses run twice a year at accredited training centres across the UK (courses are held prior to exam dates and usually run for around five days).

To find out what's right for you and where in the UK the courses are running, contact the IOA at:

Silbury Court, 406 Silbury Boulevard
 Milton Keynes MK9 2AF
 Telephone: +44 (0)300 999 9675
 education@ioa.org.uk
 www.ioa.org.uk



Environmental Noise Measurement



Workplace Noise Risk Assessment



Building Acoustics Measurement



Occupational Exposure to Hand Arm Vibration



Anti-Social Behaviour (Scotland) Act 2004 - Noise Measurements



Courtesy of LSBU 2021

IOA Events for 2022

Understandably, the 2022 conference programme is likely to be affected by the COVID-19 virus.

16 February 2022

ASK THE INSTRUMENTATION EXPERT 'QUESTION TIME' FOR ACOUSTICIANS

Organised by IOA Measurement & Instrumentation Group

30 March 2022

HEAR FOR TOMORROW

Organised by IOA and Hearing Conservation Association
Royal Academy of Music, London

20-23 June 2022

ICUA 2022

Organised by the Underwater Acoustics Group
Grand Harbour Hotel, Southampton

21-24 August 2022

INTER-NOISE 2022

SECC, Glasgow

The 51st International Congress and Exposition on Noise Control Engineering (INTER-NOISE 2022) will be held in Glasgow at the Scottish Event Campus (SEC). The SEC is located just outside Glasgow city centre in the west-end and the campus is accessible by numerous transport options.

For details:

+44 (0) 131 336 4203

internoise2022@in-conference.org.uk

<https://internoise2022.org/>

Why join the ANC?

The ANC is the only recognised association for acoustic consultancy businesses in the UK – and offers a range of member benefits.

Join us and take advantage of opportunities including

- Entry on the ANC website, where you can list the services you provide.
- ANC publications available at a discount.
- Involvement in future guideline documents.
- Regular technical presentations, discussions and networking on the hot subjects of the day at bi-monthly ANC Company meetings.
- Your views represented on BSI and ISO Committees.
- Consultation on impending and draft legislation, standards, guidelines and Codes of Practice before they come into force.
- The chance to look at new ideas and interesting themes – and celebrate the achievements of the industry – at the ANC annual conference and awards event.
- The opportunity to share ideas and good practice with other acoustic consultants.



To find out more about joining the ANC go to
www.theanc.co.uk/membership

ANC ACOUSTICS &
NOISE
CONSULTANTS

Acoustic excellence celebrated at trade body event

Acoustics professionals and academic and industry guests gathered in Birmingham to celebrate the achievements in the acoustic sector over the past year for the Association of Noise Consultants (ANC) awards.

Held at the ANC's conference at Austin Court, the winners were presented with their awards by former IOA President, Bridget Shield MBE.

For nine years, ANC has held the awards to promote and recognise excellence among UK acoustic consultants. This year, the awards showcased projects across three categories:

- acoustics for inclusion;
- building acoustics; and
- environmental noise.

A distinguished panel of judges comprising academics and professionals, as well as representatives from the sponsor companies, scrutinised the entries.

An additional two awards were presented for innovation and best presentation, with the latter being decided on the day with members casting their votes on the ANC's conference app.

Paul Shields, Chairman of the ANC, said: "The ANC awards highlight the achievements of our members in the industry.

"We've had a range of entries this year, which really reflects the diversity of the sector.

"Last year, the pandemic and restrictions meant we had to hold the event solely online, but this year we were able to present a hybrid event.

"It was brilliant to have the turnout we did for the day, as well as having the flexibility for members who could not attend in person, to still be a part of the event."



The winners were:

Acoustics for Inclusion

(sponsored by Ecophon)

- MACH Acoustics – The Deaf Academy (Winner)
- Adrian James Acoustics – Gresham's School (Highly Commended)
- Ramboll – Pupil Referral Unit, Southwark (Commended)



Building Acoustics

(sponsored by Pliteq UK)

- SRL Technical Services – Sir William Henry Bragg Building (Winner)
- RBA Acoustics – Acoustics Support to PureGym (Highly Commended)
- AECOM – Royal College of Surgeons 2020 (Commended)
- Hoare Lea – Birmingham Symphony Hall Foyer (Commended)



Environmental Noise

(sponsored by ANV Measurement Systems)

- Hoare Lea – Gunfire Noise Analysis Tool (Winner)
- Apex Acoustics – CoHut, Newcastle (Highly Commended)
- AECOM – Natural Capital Laboratory (Commended)
- Atkins – Trans-Pennine Rail Upgrade (Commended)



Innovation

(sponsored by Mason UK)

- AECOM – Natural Capital Laboratory (Winner)



Best Presentation

(sponsored by CMS Danskin)

- SRL Technical Services – Sir William Henry Bragg Building (Winner) 📍

See the event brochure at:

<https://www.association-of-noise-consultants.co.uk/anc-awards/results-2021/>



soundscape

How Does Our Environment Sound?

Binaural recordings, mobile measurement systems, (psycho-) acoustic analyses with HEADscape, standardization (DIN ISO 12913): Pioneering soundscape innovation that evaluates ambient noise quality holistically – only with HEAD acoustics.

For further information and enquiries please email us at
HEAD acoustics UK: Sales-UK@head-acoustics.com

www.head-acoustics.com



John Connell Awards

The Noise Abatement Society held its John Connell Awards at the Palace of Westminster last October.

The awards are named after the Noise Abatement Society's founder, John Connell OBE, who lobbied the Noise Abatement Act through Parliament in 1960 when noise became a statutory nuisance in the UK for the first time.

These annual awards, known as the Noise Oscars, recognise innovation and advances in acoustics. Up for grabs were awards for soundscape projects, the built environment, noise control, noise app development and much more.

The event was hosted by Colonel Bob Stewart DSO, Member of Parliament for Beckenham. Jo Churchill, Parliamentary Under Secretary of State for Defra and Member of Parliament for Bury St Edmunds, presented the awards.

The Institute of Acoustics sponsored and presented an award for the Secondary Schools Competition to mark the International Year of Sound 2021-2022 (see the cover story of the November/December 2021 issue of Acoustics Bulletin). St Oscar Romero Catholic School, the winners of the award, brought such enthusiasm to the event.

Sadly in 2020 the awards ceremony was paused due to the pandemic as with many acoustics events. For many members of the industry, this was the first time in a while that they were able to meet in person and celebrate successes together.

Gloria Elliott OBE, Chief Executive of the Noise Abatement Society, said of the event: "The John Connell Awards are even more relevant now than ever as people realise the importance of good quality sound environments to support health, wellbeing and quality of life. This extraordinary time has brought innovation to the fore and the standard of entries were truly impressive. Everyone was so delighted to see each other face-to-face, making for a fantastic evening. Our congratulations, once again, to all the deserving winners."

JOHN CONNELL LOCAL AUTHORITY AWARD 2021



(L-R) Joshua Davies (Senior Sustainability Manager, Multiplex), Jo Churchill MP, Mark Prickett (Principal Enforcement Officer, Southwark Council) and Antonio Granieri (Acoustic Consultant, SV Acoustics)

THE INSTITUTE OF ACOUSTICS SECONDARY SCHOOLS COMPETITION AWARD



(L-R) Jo Churchill MP with pupils William Clarke, Luke Bartram and Dominic Winton from Oscar Romero Catholic School and Stephen Turner (President, IOA)

JOHN CONNELL SILENT APPROACH™ AWARD 2021



(L-R) Bob Stewart DSO MP; John Bailey (Director, International Key Accounts & OEMs, HIAB); David Harvey (Lawsons) and Christopher Hanson-Abbott OBE (Chairman, Brigade Electronics)

JOHN CONNELL NOISE APP AWARD 2021



(L-R) Rob White (Environmental Health Officer, North Somerset Council); Dee Mawn (Environmental Health Service Manager, North Somerset Council); Jo Churchill MP; Lindsay Howe (Environmental Health Officer, North Somerset Council); Richard Allard (Senior Scientific Officer, North Somerset Council) and Jonathan Williams (RHE Global)

JOHN CONNELL SOUNDSCAPE AWARD 2021



(L-R) John Newman (Client Success, Anderson Acoustics); Jack Harvie-Clark (Director, Apex Acoustics) and Bob Stewart DSO MP

JOHN CONNELL FUTURE SOUND FOUNDATION AWARD 2021



(L-R) Professor Bridget Shield MBE (Professor Emerita, London South Bank University); Professor Stephen Dance (Professor of Acoustics, London South Bank University); and Bob Stewart DSO MP

JOHN CONNELL INNOVATION AWARD 2021



(L-R) Stephen Turner (President, Institute of Acoustics); John Forster (Key Account Director, Carrier Transicold UK); Simon Nash (National Fleet Engineering Manager, Sainsbury's); Scott Dargan (Managing Director, UK/ Northern Europe, Carrier Transicold UK) and Bob Stewart DSO MP

JOHN CONNELL NEXT GENERATION AWARD



(L-R) Alastair Somerville (President Elect, Institute of Acoustics); Professor Stephen Dance (Professor of Acoustics, London South Bank University)

QUIET MARK™ ACOUSTICS ACADEMY BUILT ENVIRONMENT AWARDS - ACOUSTIC MATERIALS



(L-R): Ólöf Jónsdóttir (Head of Public Affairs, ROCKWOOL); Adam Dunn (aagency, on behalf of Buzzispace) and Bob Stewart DSO MP

JOHN CONNELL STEM AWARD 2021



(L-R) Cameron Salisbury (Acoustic Consultant, AECOM); Kim Onjun (Acoustic Consultant, AECOM); Drew Waller (Acoustic Consultant, AECOM) and Graham Perry (President, ANC)

QUIET MARK™ ACOUSTICS ACADEMY BUILT ENVIRONMENT AWARDS - DESIGN



(L-R) Ólöf Jónsdóttir (Head of Public Affairs, ROCKWOOL); Jon Kaminsky (Associate, Hawkins\Brown); Adam Cossey (Partner, Hawkins\Brown) and Bob Stewart DSO MP

The winners were:

- **John Connell Local Authority Award 2021** winner: London Borough of Southwark, Multiplex (contractor) and SV Acoustics
- **John Connell Noise App Award 2021** winner: North Somerset Council
- **The Institute of Acoustics Secondary Schools Competition Award** winner: St Oscar Romero Catholic School
- **John Connell Soundscape Award 2021** winner: Apex Acoustics
- **John Connell Silent Approach™ Award 2021** winner: Lawsons Eco Truck
- **John Connell Future Sound Foundation Award 2021** winner: London South Bank University and KSG Acoustics, Quiet Project
- **John Connell Innovation Award 2021 (Sponsored by IOA)** winner: Carrier Transicold UK
- **John Connell STEM Award 2021** winner: AECOM
- **John Connell Next Generation Award** winner: CALLUX and London South Bank University
- **Quiet Mark™ Acoustics Academy Built Environment Awards 2021** winner in the *Acoustic Design* category: Hawkins Brown Architects. Winner in the *Acoustic Materials* category: Buzzispace 🌐

More details of the event and the ceremony and the winning projects can be found on the Noise Abatement Society website: <https://noiseabatement.society.org/campaigns/john-connell-awards/>



NEW IOA report writing and evaluation course

A new IOA competency course provision in report writing and evaluation will be launched in 2022.

By Dr John Pritchard MIOA and Professor Keith Attenborough, HonFIOA



to critique and evaluate acoustic technical reports.

Attendance at an accredited centre will normally be for two days, followed after at least four weeks by an additional half day (seminar) delivered online; forming part of the assessment feedback. The first presentation is anticipated to be in early 2022. If demand for the courses is sufficient, there may be two presentations of the courses per year thereafter. Centres will have discretion in respect of their modes of delivery, which can be on campus, online, or on request, at the premises of a client.

Both courses are intended to be suitable for a wide audience, but should be useful for early career employees and for those in senior positions, from a wide range of employers, including acoustics or engineering consultancies, pollution/environmental health officers and those involved with planning and development. The learning outcomes for each course are listed below.

Technical reports are an important aspect of every organisation. A report represents the final product of a project, and a poorly written one can undermine the extensive work that has previously been completed, obscure important findings and, potentially, alienate stakeholders.

Reports can be a time-consuming chore for the author, the person responsible for reviewing and authorising them and the recipient. Examples of poor reports include those which are poorly structured, those that contain too much (or too little) information, those peppered with grammatical errors and inconsistencies, and those that don't clearly highlight the key outcomes.

Following expressions of concern from various agencies about the quality of reports passing to them, the IOA has seen that the requirement for training in both

Above:
Image courtesy of
LSBU 2021

report writing skills and report evaluation is urgent, and so is launching two short courses in 2022.

Certificate of Competence in Technical Report Writing and Preparation

The aim of this course is to provide guidance on elements of good practice related to acoustic report writing and communication. The course will review the various report structures available and provide a detailed overview of what the relevant sections would normally contain. It will also consider the importance of presentation skills.

Advanced Certificate of Competence in Report Evaluation

After an overview on good practice related to technical report writing, this course aims to provide delegates with the skill set required

Competence in Technical Report Writing and Preparation course

After completing this course delegates should be able to:

- plan the preparation of a report, including determination of its scope and purpose;
- list and access suitable background and reference materials;
- understand how to tailor a report for a particular audience;
- structure a report that represents good practice and is fit for purpose;
- set out the assessment method clearly;
- select an appropriate presentation format for the data to be reported;

- identify and, if necessary, justify any deviations from any recommended measurement, calculation and/or assessment procedures;
- explain how uncertainty and measurement errors have been considered, and their possible impact on the overall outcome; and
- highlight and present the key outcomes and recommendations arising from the project.

Certificate of Competence in Report Evaluation course

After completing this course delegates should be able to:

- evaluate the scope, structure and content of a technical acoustics report and judge whether the report is appropriate to the intended audience and purpose;
- evaluate the extent to which relevant materials, including guidance documents and standards, have been utilised in the preparation of the report;
- distinguish elements of reports that represent 'good' and 'bad' practice and assess the extent to which they are fit for purpose;
- evaluate whether data has been presented in the most appropriate presentation format;
- identify and report any deviations from the recommended measurement and calculation procedure, and reflect on the implications of the deviations;
- review whether there has been adequate consideration of uncertainty and measurement errors in the report;
- assess the extent to which the report conclusions or outcomes are supported by the assessment;
- identify where grammatical errors

- and poor use of English obscure the meaning or context within a report; and
- appreciate and discuss the importance of a clearly structured report.

So far, expressions of interest in running these courses have been received from Bel Noise (Scotland), KP Acoustics Research Labs (Southampton) and Derby University. ©

For more information, please email Education@ioa.org.uk



Left: Image courtesy of LSBU 2021



REF: 162748

AN ESTABLISHED AND RESPECTED LIMITED COMPANY SPECIALISING IN FESTIVAL AND EVENT NOISE - OPERATING NATIONWIDE

- Turnover in excess of £66,000 for 25% FTE input.
- Provides expert advice throughout the planning and delivery of music events, as well as working with architecture practices and solicitors.
- Loyal and long-standing client base.
- 85% of sales are derived from existing clients.
- No active marketing other than brochures and website, leaving room for significant expansion.
- A fully relocatable opportunity which can be effectively managed from any location and ideal for home working.
- Offered for sale to facilitate retirement plans.
- Excellent opportunity for turn-key first business or for existing consultancies to acquire new specialised expertise and customer base.
- Handover support to migrate business to a new owner.

All enquiries should be directed to:
 Jesse Daley
 Commercial Executive
 Tel: 01204 555 084
 E-mail: daley@knightsbridgeplc.com

EEMC MONITORS
 SALES | SUPPORT | CALIBRATION

Cloud-based Monitoring of Vibration & Dust
 High quality, with exceptional value for money

Innovative, straightforward and practical monitoring solutions

UK & ROI Sales, Support & Calibration
www.eemc-monitors.co.uk
info@eemc-monitors.co.uk | 0208 012 7933
 Suite 5, 5a Lombard Road, Wimbledon, SW19 3TZ

Peter Barnett Memorial Award 2020/21

The Institute of Acoustics is delighted to present Wolfgang Klippel with its Peter Barnett Memorial Award 2020/21 for his outstanding work in this field.



Above:
Wolfgang Klippel

inaugurated in 2001 by the IOA Electro-Acoustics Group, The Peter Barnett Memorial Award honours Peter Barnett who died the previous year. This award, which is made annually, recognises advancements and technical excellence in the fields of electro-acoustics, speech intelligibility, and education in acoustics and electro-acoustics.

Citation for the award:

Wolfgang Klippel studied Electrical Engineering at the University of Technology in Dresden, Germany, from which he received a degree in the field of Speech Recognition in 1982. After graduating, he joined the Loudspeaker Research Group of VEB RFT in Leipzig, where he carried out research into transducer modelling, acoustic measurement and psychoacoustics.

In 1987, he received a PhD in technical acoustics for his thesis: 'Multidimensional Relationship Between Subjective Listening Impression and Objective Loudspeaker Parameters.'

He continued researching into the audibility of nonlinear loudspeaker distortion and started modelling the nonlinear mechanisms in low frequency transducers and horn loudspeakers.

He summarised the results of his research in a thesis: 'The Nonlinear Transfer Characteristic of Electroacoustic Transducers,' for which, in 1994, he was awarded a Certificate of Habilitation, a prestigious qualification required in Germany in order to conduct self-contained university teaching.

In 1993, Wolfgang received the Audio Engineering Society

(AES) Publications Award for his outstanding paper: 'The Mirror Filter – A New Basis for Reducing Nonlinear Distortion and Equalizing Response in Woofer Systems.'

After spending a postdoctoral year with the Audio Research Group in Waterloo, working on nonlinear sound propagation in horns, he went on to work at Harman International on the nonlinear control of loudspeaker systems. He then moved back to Dresden in 1995, where he became an independent consulting engineer.

In 1997, he founded Klippel GmbH, an innovative company that produces novel control and measurement systems for transducers and loudspeakers. This company has successfully grown over the years and now employs a team of over 30 people.

In 2013, Wolfgang gave the distinguished Heyser Memorial Lecture entitled: 'Small, Loud-Speakers: Taking Physics to the Limit' at the 134th AES Convention in Rome.

Wolfgang Klippel is currently an AES Fellow and participates actively in the AES Standards Committees. Since 2007, he has been engaged as a professor of electroacoustics at the University of Technology in Dresden where he is currently giving lectures in:

- Active Control of Sound and Vibration; and
- Sound Quality of Audio Systems.

Wolfgang's contribution to the field of electroacoustics, both through his research and teaching activities, is truly world class. His papers and tutorials on loudspeaker modelling and measurement – particularly those on large signal behaviour and physical distortion mechanisms – are considered reference works in the field. ©

Award for Services to the Institute of Acoustics

The Award for Services to the Institute was introduced so that the IOA could publicly acknowledge the debt owed to individual members who have provided sustained assistance over the years in some way with the running of the Institute.

Robin Cross FIOA was educated at Southall Grammar School, Willesden College and Suffolk College where he gained an HND in Communications Engineering.

He joined the Post Office Research Station at Dollis Hill as an apprentice in 1964.

This three-year apprenticeship included a broad education in communication systems, including objective and subjective sound quality evaluation.

He looks back at this time as invaluable and formative due to the breadth of ideas, techniques and systems employed to solve complex problems.

Robin joined the acoustics laboratory of the Station where his duties included microphone calibration using a Rayleigh Disc system and developing electret microphones, ear and mouth simulators.

In 1974 Robin acquired an evening job building experimental outboard audio equipment at Scorpio Sound Studios in Euston. Working alongside the likes of Queen and Supertramp made Robin think seriously about a change of career direction into the recording world.

He eventually took the safer option of staying with Post Office Research. During this time, he kept his trusty Revox and an assortment of microphones in the car boot and recorded live bands whenever he could.

1976 saw the Post Office Station move to Martlesham Heath, Suffolk where two brand new anechoic chambers and a reverberation chamber were available for research.

Now promoted to Executive Engineer, he now managed the Sound and Vibration Laboratory; the vibration part referring to

maintaining the integrity of countrywide BT underground assets threatened by nearby planned demolition and construction.

Robin was a member of the BSI Electro-Acoustics committee EPL/29 developing UK standards for ear simulators and Sound Level Meters. He was also a member of the BSI Acoustic Shock Panel TCT/1. He joined the UK delegation on the International Telecoms Union Study Group 12, end-to-end telephony speech performance, where the specification for the Head and Torso Simulator was developed.

This experience led to the development of a range of computer-controlled telephone and GSM (Global System for Mobile Communication) handset test equipment for performance characterisation.

Robin has always been interested in high quality sound reproduction which was the driver for him to go to the Reproduced Sound (RS) Conference in Windermere, once he was aware of its existence.

He has attended nearly all of the RS conferences since.

He joined the RS committee in the 1990s which he later chaired for three consecutive years from 1999. After a short holiday, Robin re-joined the committee in 2015 for a further four years.

Leaving the good ship BT Research in 2000, he became self-employed and worked with NXT in Huntingdon for four years, then for a series of acoustic consultancies in London and Essex. During this time, he became a STEM ambassador for Suffolk Schools. He is a former member of the Audio Engineering Society and the Acoustical Society of America.

During 2010 to 2018 he was involved in consultancy work, solving a wide range of customers' problems.



Above Below:
(L-R) Robin Cross
FIOA and
Stephen Turner,
IOA President

The Sound Level Meter has now retired except for an annual outing to the FolkEast Festival to take care of the Offsite Noise Management.

Robin's acoustics experience has proved useful when dealing with planning applications in his role as a Parish Councillor in Suffolk, where he now lives.

Robin has contributed a great deal to the field of acoustics and to the running of the Institute. He has worked tirelessly in pursuit of workable techniques and systems to solve complex problems in many areas of the field.

This anonymous quote, found online, sums up his achievements: *"Robin is a creative genius who dedicates his working life to achieving the highest standard possible. He gives his all to each project or role he takes on. His knowledge of acoustics is based on many years dedicated research and hard work plus a genuine love of the subject. On top of this he is also a really nice bloke."*

The Institute of Acoustics is delighted to present its Award for Services to the Institute to Robin Cross. ☺

Sustainability calling – want to do and learn more?

Join the Inter-noise 2022: ‘Noise Control in a More Sustainable Future’ Sustainability Strategy working group.

As reported in the November/December 2021 issue of *Acoustics Bulletin* (page 20), the IOA is organising Inter-noise 2022, the 51st International Congress and Exposition on Noise Control and Engineering in Glasgow on 21-24 August 2022.

This year’s timely theme is ‘Noise Control in a More Sustainable Future’, which is very apt; as the venue is the same that hosted the COP26 conference on climate change in November 2021. It has been decided that it would not do to ignore the challenge of the direct impacts caused by holding this international conference, given its topic, so a working group has been formed. The working group, tasked with benchmarking and minimising the carbon footprint and maximising the green credentials of the event, is being formed by the IOA in partnership with Sustainable Acoustics, and we are recruiting those interested in assisting us from members now.

Do you have enthusiasm for sustainable change? Come and plug your motivation, energy and passion for innovation and collaboration into the Inter-noise Sustainability Strategy working group.

Create transformative change

Whether you’re working in your organisation at an operational or director level pursuing sustainability objectives to decarbonise your business, or are new to sustainability and are simply hungry to learn more and implement sustainability into your own company, the working

group wants to hear from you if you are keen to be an active member.

If either sounds like you, contact Paul Lepper, Chair of the working group. You will use your passion to create transformative change and build CPD hours that will make a real difference and help realise Inter-noise’s objective to ‘Deliver a More Sustainable Future’ and legacy to encourage INCE into the future.

Our vision for the Sustainability Strategy working group is to:

1. Minimise operational event greenhouse emissions including transportation to the venue, energy use in the venue and food consumed in the venue;
2. Create a baseline carbon emissions footprint for Inter-noise 2022;
3. Emission reduction targets for 2023; and
4. Signpost for a future net-zero pathway.

To register your interest, email Paul Lepper, Chair of the Sustainability Strategy working group at P.A.Lepper@lboro.ac.uk

Background

Climate change is already harming societies and the global economy. Evidence shows that humanity is taking grave risks with the stability of the Earth’s life support system if global average surface temperatures continue to rise. Reducing this risk means working together to stabilise temperature rise to a maximum of 1.5°C above pre-industrial temperatures.^[1]

The UK acoustics industry contributes £4.6 billion to the country’s economy annually,

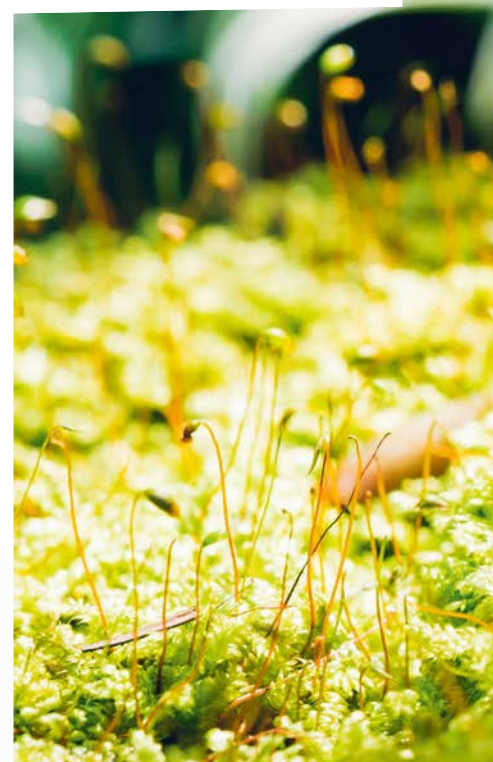

References

1 IPCC. Summary for Policymakers. In *Global Warming of 1.5°C. An IPCC Special Report on the impacts of global warming of 1.5°C above pre-industrial levels and related global greenhouse gas emission pathways, in the context of strengthening the global response to the threat of climate change, sustainable development, and efforts to eradicate poverty*. Geneva, Switzerland: World Meteorological Organization, IPCC (2018). [https:// www.ipcc.ch/sr15/](https://www.ipcc.ch/sr15/)

employing more than 16,000 people, each generating over £65,000 in value in 750 companies nationwide.

Inter-noise 2022 has a pivotal part to play in the acoustic industry, and, as such, has a valuable opportunity to engage its member organisations with sustainability and decarbonisation of the acoustics industry towards a 1.5°C ambition and net-zero pathway.

This is especially important for Inter-noise 2022, as the event and services are influencing consumer

and company decisions across the built environment.

To achieve the 1.5°C ambition, global greenhouse gas emissions should peak by 2020 and halve by 2030 to reach net zero by 2050, while at the same time, removing some of the carbon already emitted into the atmosphere. Any delay will increase the risk of dangerous climate change and require even more dramatic reductions. Doing this will require the fastest economic and societal transition

in history – but one which is both necessary and achievable and will bring significant benefits from reduced biodiversity loss and pollution to improved health and economic development. [2]

Sustainable Acoustics commits to halve its greenhouse gas emissions by 2025 and reach net-zero by 2030. ©

References

2 Burke et al., Large potential in economic damages under UN mitigation targets. <https://www.nature.com/articles/s41586-018-0071-9.epdf>





Join us for Inter-Noise 2022 in Glasgow

The Congress theme is **Noise Control in a More Sustainable Future**

The 51st International Congress and Exposition on Noise Control Engineering (Inter-Noise 2022) will be held in Glasgow, UK at the Scottish Event Campus (SEC) from 21-24 August. The SEC is located in the west end of Glasgow city centre. The campus is accessible by numerous transport options.

KEY DATES:

1 December 2021	Call for abstracts
1 December 2021	Registration opens
4 February 2022	Abstract submission deadline
4 March 2022	Abstract notification
4 March 2022	Paper submission opens
28 March 2022	Paper submission deadline (requiring assessment)
29 April 2022	Paper submission final deadline
29 April 2022	Assessed paper submission final deadline following feedback
29 April 2022	Early bird registration for authors
8 July 2022	Early bird registration for non-authors



For more information contact organising secretariat In Conference:

In Conference Ltd, Unit 1, Q Court,
Quality Street, Edinburgh, EH4 5BP

Tel: +44 (0) 131 336 4203

Email: internoise2022@in-conference.org.uk

<https://internoise2022.org/>





architectural acoustic finishes

Herbal House offices, London.

SonaSpray K-13 in grey applied directly onto old concrete slab to refurbish and acoustically treat this stunning two-storey, Manhattan loft style office.

Whether it be for a fit-out, refurbishment or new build, taking office acoustics seriously can significantly improve the occupants health and productivity.

With our range of 5 spray applied, acoustic decorative finishes from textured industrial chic, to the smoothest acoustic plaster on the market, there is a finish to suit every project and budget.

Credit to TP Bennett, BW Workplace Experts & Tom Green Photography.



OSCAR
acoustics

IOA Early Careers Group future events survey

After a successful year of webinars, the IOA Early Careers Group (ECG) survey was recently undertaken to determine how the Committee can continue to use its platform to support its members in the future.

By Josie Nixon, IOA Eastern Region Early Careers Group Representative

Over the past year (2020/2021) a wide range of work and events have been undertaken including:

- the art of being a consultant;
- 'Ask Anything';
- further education in the time of a pandemic;
- effective collaboration between academia and industry and future research innovation;
- Covid-19 survey and future activities;
- upgrading your IOA membership; why, how and when; and
- mapping the sounds of our universe.

Although the Group's survey predominantly focused on the ECG webinars, it is also important to mention the 'Art of being a Consultant' mini-series.

Due to restrictions with social distancing, the online series substituted the well-established, in-person event and covered a variety of non-technical topics ranging from working remotely, to how to get a job and networking. These events tended to be held in the daytime and were well attended – a thank you once again for everyone who attended and presented.

The survey results

The survey received 49 responses. Almost all of the respondents were ECG members and about 40% of them had attended at least one of the ECG events in 2020-2021. The survey asked what they enjoyed from the past sessions and also asked what they would like to see in terms of events and formats in 2022.

There was a mixed response to the question concerning the type of session that ECG members would like to attend online (panel discussion, presentation, networking and workshops, so the ECG Committee therefore plans to provide a mixture of sessions covering all the above styles. For those of us who actually ran the events last year, most felt a mixture of styles worked well.

Although the results were quite close, the survey showed that the most popular and well-attended event was 'Upgrading your IOA Membership' and this was also the event that respondents would most like to see repeated.

The survey asked ECG members what topics they would like to see covered in future sessions and the response once again varied (as seen in the chart below):

Q8 What topics would you like to see covered in future sessions?

Answered: 49 Skipped: 0

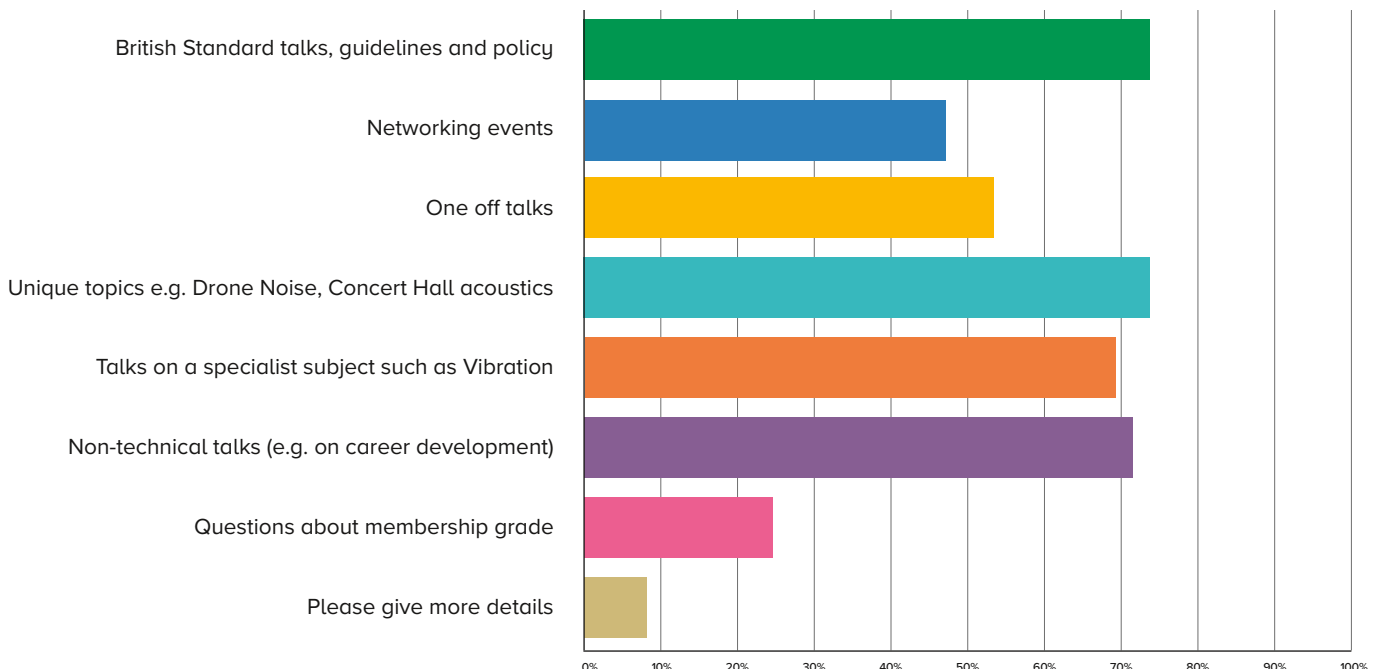

We therefore plan to provide a variation of talks going forwards, focusing initially on the subjects identified as most popular:

- British Standards;
- unique topics;
- non-technical topics; and
- talks on specialist subjects.

If anyone has a specific request on topic (for example a British Standard), or would like to give a talk then please get in touch on earlycareers@ioa.org.uk

Some useful comments and feedback on webinars were also given in the survey e.g. that they should provide a platform for the

ECG members to highlight their work. The Committee completely agrees and would like to invite ECG members to present topics of their choice – if you have something you would like to present or discuss, then please get in touch.

In order to allow everyone to join the future events, the timings will alter and will be held either at lunchtime or in the early evening to provide a variation. We will also aim to record as many events as possible.

Finally, we asked about the Groups social events. Some 52% of respondents said they would like an

online social and we are pleased to report that our first event was just that. We held an informal online get-together on 8 December 2021 with a quiz thrown in after the more formal presentation of the results of our ECG Future Events survey (outlined in this article).

After three rounds of questions, the fastest and most accurate participant was Daniel Moiseiwitsch, followed by Nikhil Banda and Sebastian Duran. The event was prepared by our group of hard-working volunteers; Josie Nixon, Daniela Filipe, Zach Simcox, Aaron Tomlinson and Diogo Pereira.

Q9 Would you like an online social session (e.g. pub quiz style)

Answered: 48 Skipped: 1

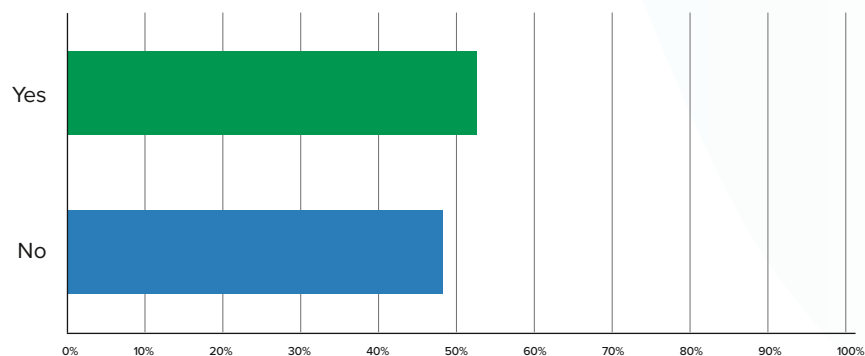

ANSWER CHOICES	RESPONSES	
Yes	52.08%	25
No	47.92%	23
TOTAL	Yes	48

Upcoming events

We will be hosting a range of events over the next year based on the results of this survey, and hope to see many more of you taking part.

We are hard at work organising our January webinar and by the time this issue is published, you should have seen a notice about the event – we hope to see you there!

We are also hoping (restrictions permitting) to hold a face-to-face ‘Art of Being a Consultant’ event in March 2022 and will be sending out more information out on this in the New Year, as well as publishing the dates for the next few ECG online events.

ECG new members

The ECG is open to all members of the IOA (both corporate and non-corporate) who shall normally be under 35 years of age or within first five years of their career. The group is always keen to hear from members and non-members alike. To join the Early Careers Group, to find out more information or to voice your concerns, visit <https://www.ioa.org.uk/early-careers-group>



There are ECG vacancies at Central Branch, North West, Research Committee and Physical Acoustics Group – if you are interested, please get in touch with the ECG or the relevant groups directly.

The ECG is always on the lookout for CPD ideas – please email us on earlycareers@ioa.org.uk if there are any technical, career and education-related topics you would like to be discussed.

Virtual work experience for 1,000 students

In this issue, IOA STEM committee member, Vicky Wills, reports that the IOA STEM Committee has just been given the go-ahead to organise virtual work experience for up to 1,000 GCSE and A-Level students, in 2022, with an organisation called Springpod.



This virtual work experience will not be anything like traditional workplace work experience. Instead, it will be an overview of the acoustics industry and will give our industry the opportunity to engage with a large number of students from anywhere in the UK. It is hoped that if we all come together as an industry, and show young people the huge range of careers in acoustics, we will be able to inspire a pipeline of future acousticians.

The work experience will be designed to run over two weeks, for one hour a day, and will include engaging content including videos, games, activities and live webinars. Following the course, Springpod will create a GDPR-compliant talent pool of the students that are interested in acoustics, and we can let them know about any events,

Above: This virtual work experience will give our industry the opportunity to engage with students from anywhere in the UK

traditional work experience or apprenticeship opportunities.

Module content

We have already been working with a few groups within the industry to design the modules, and are looking for more people to help. The modules are:

- **Introduction to acoustics** – why we do it, introduction to the IOA, the range and breadth of projects and careers, an overview of the elements that we don't have time to cover in detail, how music fits in, the measurement of sound and an introduction to modelling.
- **Acoustics and the environment** – policy, law and planning, receptors, sources of noise, noise control, underwater acoustics, modelling and soundscaping.

- **Acoustics and architecture** – policy, receptors, important elements of buildings, modelling, noise control, sound artists.
- **Acoustics and innovation/technology** – audio engineering, voice recognition, music, sound in games, car design, everyday quiet innovation.
- **Acoustics and health** – ears, hearing and impairment, health and wellbeing (including music), medical acoustics, the importance of sound for diagnosis and therapy.
- **Pathways into acoustics** – role of the IOA, pathways and routes into acoustics.

We need your expertise and enthusiasm

We really need volunteers to create videos, help us create content and present at our webinars and panel events. If you are interested in getting involved and supporting this initiative, please get in email STEM@ioa.org.uk

These lists are not exhaustive, and will evolve as the content is created. If there is anything that you are keen to have included in the modules, especially if you are willing to create (or already have) some content, **please get in touch at STEM@ioa.org.uk**

It is very important to all involved that we show the diverse range of careers and career routes for acoustics, but it is really essential that we show a diverse range of role models that work within the industry and make sure that the experience is inclusive for all.

If you can help with this, **we really want to hear from you!** 🗣️

It's time to renew your membership

Your membership expired 31st December 2021 and renewals will be issued from Mid-January 2022

Membership of the IOA enables professional recognition and greater influence in shaping the world in which acousticians work and live.

Membership also brings a wealth of additional training resources as well as unrivalled opportunities for professional career development and networking.



Environmental noise



Electro acoustics



Measurement and instrumentation



Musical acoustics



Underwater acoustics



Noise and vibration engineering



Physical acoustics



Building acoustics



Speech and hearing



Silbury Court, 406 Silbury Boulevard, Milton Keynes MK9 2AF
Telephone: +44 (0)300 999 9675 | membership@ioa.org.uk | www.ioa.org.uk

Building Acoustics Test Solution



www.nti-audio.com

NTi Audio UK, Stevenage, Hertfordshire, UK
T: 01438 870632 E: uk@nti-audio.com

Complies with ADE & ISO 16283

Government policies

The IOA actively monitors developing government policy across England, Ireland, Scotland and Wales. Mary Stevens, IOA Policy Support, reports.

It's been a busy couple of months for consultations. UK Governments are actively reviewing energy, planning and transport policies, to bring them in line with targets for decarbonisation. This has meant plenty of work for the IOA members helping to draft our consultation responses, and raise the profile of acoustic issues in emerging policy. Here you can find a short summary of responses submitted in November 2021. These are posted as 'news' on the IOA website, with links to our full responses.



further research is required into noise impacts from drones, and recommend an industry working group is set up to develop guidance on the prediction, assessment, monitoring and management of drone noise. (<https://www.gov.uk/government/consultations/future-of-transport-regulatory-review-future-of-flight>)

National Policy Statements for Energy

Energy National Policy Statements (NPS) are being reviewed by Government to ensure the planning policy framework supports infrastructure required for a transition to net zero. In responding to the consultation, IOA welcomes acknowledgement that acoustic issues must be considered throughout the draft policies. Amendments to wording are advised for consistency with existing policies. In particular, on the draft policy on generic impacts of energy infrastructure, it is suggested language used is consistent with that in existing planning guidance and the Noise Policy Statement England. Amending wording on the role of green space in noise mitigation is also advised, from stating that green space can 'absorb noise' to advising it 'can contribute to a small extent to noise mitigation'. This avoids raising expectation that planting greenery is a panacea for noise reduction. These statements apply to England and Wales. (<https://www.gov.uk/government/consultations/planning-for-new-energy-infrastructure-review-of-energy-national-policy-statements>)

Gym Acoustics Guidance

Comments were submitted on the draft guidance for acoustics in gyms, drafted with ANC and CIEH. The selection of definitive noise criteria is welcomed. It is recommended that the same definitive approach is taken regarding vibration limits, and it is noted that there is no reference to suitable equipment type and specification when measuring vibration. A better explanation as to why the LA_{max}, fast noise limits for lifts as recommended in BS 8233: 2014 are mentioned would be helpful. It is also suggested that some guidance is given on what constitutes a low background noise level, and that detail on definition of floor stability would be helpful. (<https://www.association-of-noise-consultants.co.uk/wp-content/uploads/2021/09/Gym-Acoustic-Guidance-Consultation-Draft.pdf>)

Scottish Building Regulations – Heating and Ventilation – Consultation Response

IOA Scottish Branch responded to proposals for the review of energy and ventilation standards set through Scottish building regulations. These seek to deliver further improvement to energy efficiency of new buildings. The response highlights the need for building owners to be made aware that new heat sources may have noise impacts, and establish

whether new plant is permitted under the Micro Certification Scheme (MCS) or planning assessment is required. On ventilation, it is advised that on commissioning there is value in sample testing a proportion of properties, as per current sound insulation testing for party wall and floors. Proper consideration of the relationship between ventilation, overheating and acoustics is also advised – as set out in the IOA and ANC 2020 Acoustics, Ventilation and Overheating Residential Design Guide.

(<https://consult.gov.scot/local-government-and-communities/building-regulations-energy-standards-review/>)

Regulatory review on the Future of Flight

As part of a regulatory review of the Future of Transport, the Future of Flight examines areas where regulation is outdated, a barrier to innovation or not designed for new technologies. Responding to the consultation, IOA recognises that the growing use of drones has potential to cause noise disturbance and health impacts for communities across the UK. The inclusion of noise regulation measures in the consultation is therefore welcomed. Given commercial aircraft are exempt from statutory nuisance, clarity is sought as to whether drone operations would also be exempt. IOA also advise that



About the author: Mary Stevens supports the IOA to bring acoustics to the attention of policy makers.



Structural Vibration Isolation

It is becoming more and more common for whole buildings to be isolated against the vibration from train lines and road vibration, as typically more cost effective and space efficient than introducing isolation breaks internally. A prime example of structural isolation is the prestigious 55-93 Knightsbridge project. The development involved the demolition of the existing early Edwardian structure, whilst retaining the elegant façade.

The new isolated structure had cores, shear walls and first floor supported on 8Hz bearings and was resiliently connected back to the retained façade. The building was not originally designed to be isolated, but vibration from the adjacent tube line and road would have re-radiated as undesirable noise levels within the building, a 25dB(A) criteria applied. The project was challenging in that the isolation line had to be accommodated with minimal disruption to the existing design.



The value of the property meant that millimetres mattered. We went through enormous efforts to reduce the envelope required for bearing assemblies

within the building. The column capitals included the bearings supporting the structure above, lateral restraints, tension anchors to meet disproportional collapse requirements, fire protection and first fit architectural finishes.

There were approximately 60 columns and each one was engineered differently to save space. Multiple wall interfaces were also isolated; we engineered the bearings and special telescoping lateral restraints which fitted within the existing wall width.



- ▲ Render of the completed building, courtesy MSMR architects
- ◀ Mason bearings being placed in one of the core pits
- ▼ Wall and column isolation systems engineered for compactness.



This project is an example of how we can solve many challenges through good design and coordination. We would be pleased to discuss in more detail or if we can help with any other building isolation project.

ABOUT MASON

A world leader in noise & vibration control products for over fifty years setting the standard for consultants & architects. In addition to a complete range of mounts, our floating floors, walls & suspended ceilings provide total acoustic isolation.

TYPICAL APPLICATIONS:

- Music Rooms • Night Clubs • Plant Rooms • Recording Studios • Bowling Alleys • Building Isolation
- Cinemas • Gymansia • Microscopes • M+E Isolation • Suspended Ceilings • Industrial

The IOA video Acoustics Bulletin, episode 2 review

As part of the IOA’s ambitious plans to broaden its reach for members, the wider acoustics and acoustics-related communities, and the public, the second episode of the video Acoustics Bulletin has just been released.



Presented by Rich Keeble, the 30-minute video updates viewers on a wide variety of industry developments through interviews with a mix of experts and those newer to the field.

Women in acoustics

According to recent UKAS data, provided by the Higher Education Statistics Agency, between 2012 and 2018, 39% of students studying physical sciences were female. In the same period, the percentage of female students studying mathematical sciences was 37% and only 5% of audio engineers in the UK are women. This shortage of women expands to other areas of acoustics, but the opportunities abound. In the video, Professor Bridget Shield MBE says: “It has been encouraging to see a gradual increase in the

Above:
Presenter, Rich Keeble

Above right:
Peter Rogers at Winchester Science Centre

number of women in our industry, but acoustics in general is hidden, people aren’t necessarily aware of it as a subject that can be studied at university. We need to promote acoustics and raise awareness of it, and one of the things that might make it more attractive to all, but to women in particular, is its links with other subjects such as psychology and the effects of noise on people. This is very rewarding work and feeds into the Building Regulations on the acoustic design of schools, showing that it has an impact on the real world.”

Improving diversity

The lack of women in the sciences stretches into engineering and Jennifer Glover, IOA student member, has been working to improve diversity in the field and the video shows her explain how she

approaches this work. She says: “I am involved with the Women’s Engineering Society, which helps to support women through all stages of their career, and, for me, that gives me a real opportunity to try not only to make engineering better for me as a female engineer, but also making it a better industry all round.”

Research

Another woman excelling in the field of acoustics is Hasina Begum who is breaking ground with her aerogels research. Aerogels are among the lightest solid materials known to man and are used in acoustic and thermal insulations, the manufacture of chemical products, electronics, energy absorbers and in buildings systems. Hasina’s video interview covers her PhD research work, where she explains how aerogels absorb sound and how her

research differs from previous work. Rather than focusing on aerogels in composite form, her work concentrates on their granular and powder form.

Soundscapes

Jack Harvie-Clark has been researching improving residential noise impact assessment by using a soundscape approach to design, which is fundamentally different to a traditional acoustics design approach. In his interview for the video Acoustics Bulletin, he explains how his research informs architects, who then may change the fabric of a proposed development to provide additional noise control in certain places, or change a way a development is used – quite different from a noise control approach.

Winchester Science Centre

The middle part of the video is introduced by Peter Rogers, who describes the Winchester Science Centre (WSC) as a “cathedral of science”, he explained that by considering each of the pillars of sustainability we can begin to think of the many ways we can use acoustics to achieve better outcomes. This section includes a virtual tour of the sound, hearing and vibration exhibition installed in 2020, with Sara Mela, WSC’s Curiosity Officer as a guide.

Awards

Recipient of the 2021 Rayleigh Medal, Professor Michael Vorlander, speaks about his award for the video and how all awards given by acoustics organisations are

very important in order to motivate young people and early-stage researchers to work hard and establish well recognised academic records. He speaks about his career in the 1980s, when the first desktop and personal computers started to become available for research applications; and it became possible to add more and more features, which meant that engineers no longer had to rely on calculated data but could also listen to sounds created by computer simulations. He says: “I worked hard to advance these models and later used the same technology for automotive applications and for hearing research.”

The power of acoustic tools

The Bristol Acoustic Manipulator (MAP) is a new device being developed by the Ultrasonics and NDT Group at the University of Bristol. Researcher and one of the co-creators, Luke Cox, explains acoustic manipulation and how it is applied in his research into new techniques of moving small and delicate particles. Bringing a practical example to illustrate his research, Luke explains its use in tissue engineering where acoustic forces can be used to ‘pattern’ particles to force the tissues to grow in a realistic way, rather than in simple straight lines.

Sustainability

Dr John Lincoln has been researching the effects of the pandemic on the acoustics and phonetics industry and in his interview, he describes the new recently published Government

innovation strategy that focuses on transformative technologies and how we can build on the fact that the UK is great at science and turn that into economic advantage.

He speaks about sustainability, which has shifted from the periphery to a mainstream concern. Every business must look hard at their sustainability strategy and examine what they are doing on the technology front to move those to the fore. This will have a big impact on acoustics’ he says, and any enabling technology.

Practical applications

Eleanor Gidziusz is a principal acoustics engineer, who speaks about one of her recent projects. She has been working at the Royal College of Surgeons HQ in a busy part of London and had to work out how control the amount of external noise getting into the building. During a video tour of the main atrium, she explains the project and explains how 3D modelling was used to simulate sound travel in the space so she and her team could work out where to treat the existing hard finishes.

With a contribution by IOA President, Stephen Turner as well, this episode illustrates the diversity of the acoustics industry, without being overly technical for a lay audience. It is a half hour gallop through some of the most interesting and inspirational aspects of what is sometimes, hidden work, and it is just enough to encourage the audience to begin to grasp the sheer diversity of acoustics. 🌐

Below:
Dr John Lincoln

Below right:
Eleanor Gidziusz



Watch the video here:
<https://vimeo.com/651049587/9bd758194a>

Do you think we'll ever see calibratable MEMS type chip mics capable of replacing half inch mics? If not, why not?

This was one of the questions posed to the Measurement and Instrumentation Group panel earlier this year at the 'Ask the Instrumentation Expert' meeting reported in the November/December 2021 issue of Acoustics Bulletin (Page 28). This seems to be one area of genuine innovation in sound level meters, and we have received several requests to expand on the subject, hence this Instrumentation Corner article.

By John Shelton of AcSoft Group, with input and help from Martin Williams of Cirrus Research and Ben Piper of Acoustic Sensor Networks

On the committee, we have a few members with expertise in the subject, such as Martin Williams of Cirrus Research¹, and Ben Piper of Acoustic Sensor Networks, so we put out heads together to tease out some of the issues.

What is a MEMS microphone?

MEMS stands for 'micro electro mechanical systems', and the title covers all miniature devices with mechanical parts, including mirrors, gears and, of course, sensors. Sensors are available for measurement/sensing of sound and vibration, and they all have the

manufacturing technique in common, which typically involves a silicon wafer fabrication process. The main advantage is size, and cost saving through volume manufacturing, and you will find them in inkjet printers, tyre pressure sensors, gyroscopes and microphones.

In principle, a MEMS microphone is no different to the traditional condenser microphone, in that it's a capacitor. The incident sound will cause a variation of the capacitance, which we can use to sense the variation in pressure.

Because the sensing element is so small, even with some complex designs of etching, the sensitivity of the microphone is low, around

7-8mV/Pa (this compares to a traditional ½" microphone at 50mV/Pa)

However, this is more than enough for the applications for which it has been designed. These include mobile phones, headsets, headphones, wearable devices and home smart devices. In fact, your typical smartphone will contain several MEMS microphones, to help with noise cancellation and source location.

Sometimes, you will hear the term 'digital microphone'. This will be a package, which contains the microphone itself, with its conditioning (preamp) and on-chip analogue-digital conversion. In other words, sound goes in, digits come out. This has implications later on when we come to calibration.

The manufacturing process ensures massive volume, repeatability, reliability and low cost. Compare that to a traditional measurement microphone, which will essentially be hand-built in very low volumes.

Characteristics of MEMS microphones

The main considerations of microphone performance are:

1. frequency response;
2. level measurement range;
3. directional characteristics; and
4. environmental stability [P48](#)

Below:
Figure 1: A typical MEMS sensor chip

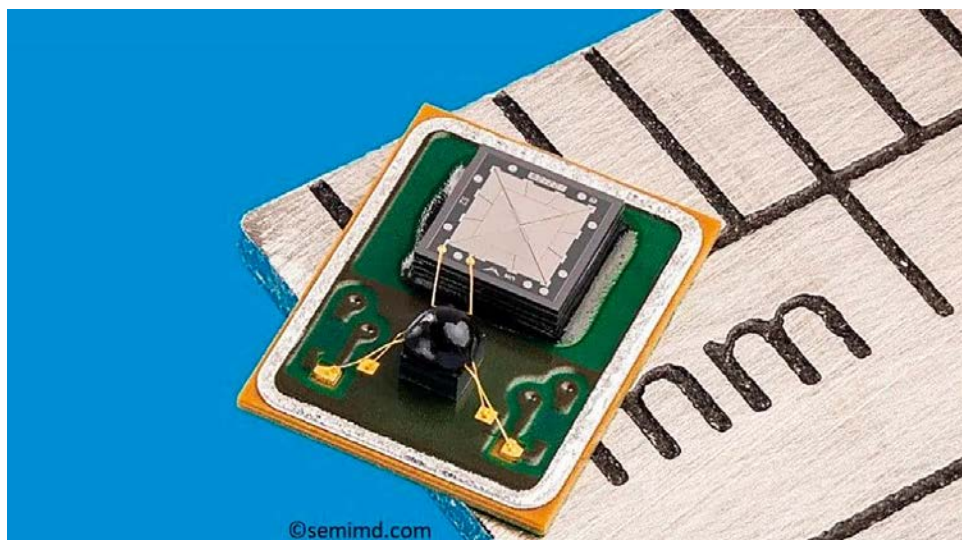

SIMULATION CASE STUDY

Simulation + testing = optimised loudspeaker designs

A global leader in electronics rose to the top of the audio industry by adding multiphysics simulation to their design workflow. COMSOL Multiphysics® enables audio engineers to couple acoustics analyses and other physical phenomena to address design challenges inherent to loudspeaker and soundbar designs.

LEARN MORE comsol.blog/loudspeaker-design

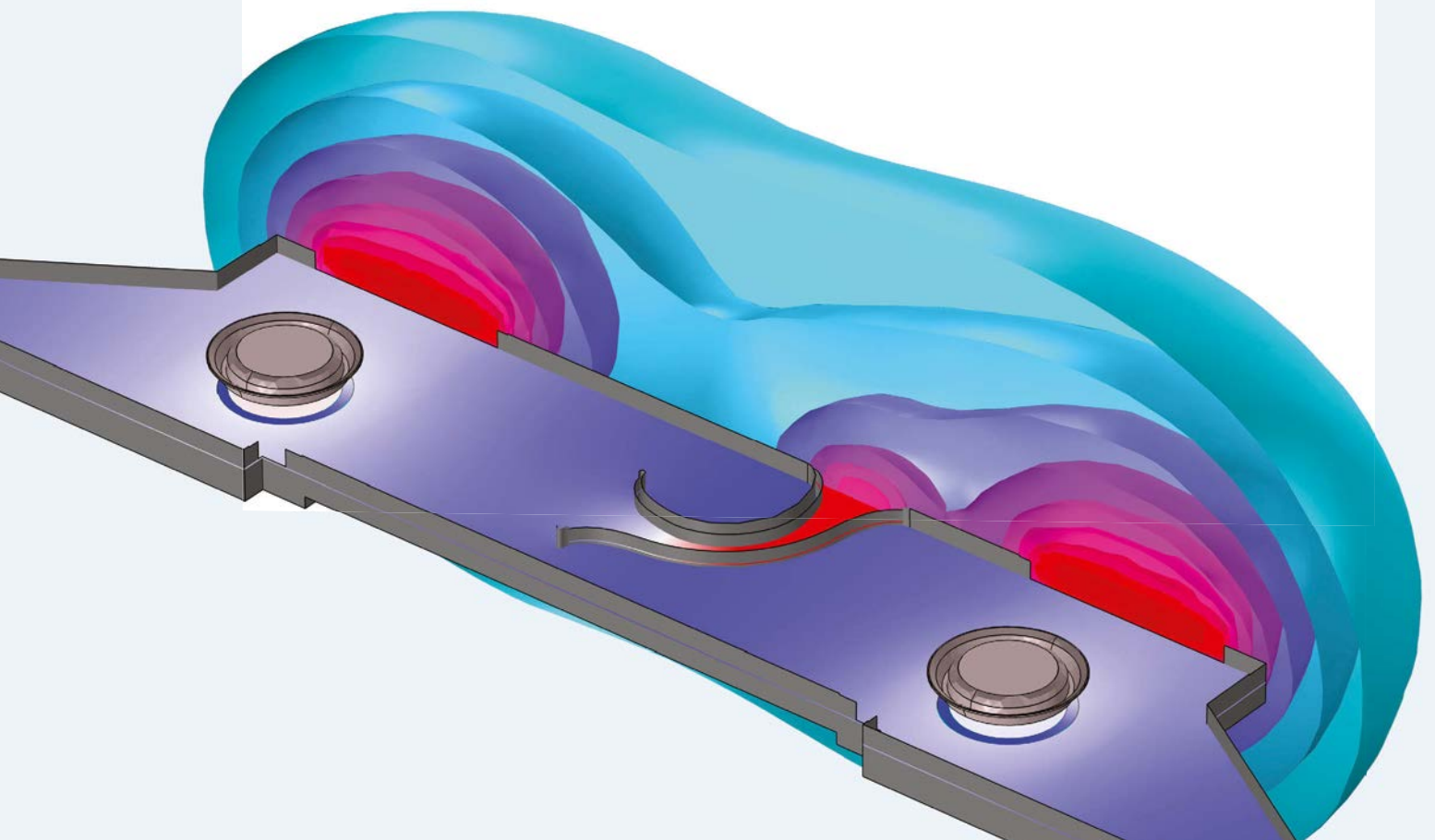

 COMSOL

The COMSOL Multiphysics® software is used for simulating designs, devices and processes in all fields of engineering, manufacturing and scientific research.

Frequency response

The response of a MEMS microphone shows a low frequency roll-off, anywhere between 20-100Hz, a linear pass band, and then a high frequency resonance, anywhere between 20-50kHz.

The low frequency roll-off is useful for wind noise and sibilance reduction, and the high frequency resonance is a function of the size of the sensing port and packaging, as well as the silicon structure. You could make a comparison here with a piezoelectric accelerometer which shows similar HF behaviour.

For use as a measurement transducer both of these have to be controlled, either with acoustical filtering or digital signal processing. However, controlling resonances eats into dynamic range and noise floors.

The choice of analogue or 'digital' MEMS microphones is salient here, the latter requiring the use of digital filtering, which may have power supply implications.

Level measurement range

MEMS microphones typically have an upper limit of sound pressure level of around 130 dB, and a noise floor around 30-40 dB, so clearly inferior to a condenser microphone, where we are used to making measurements from 20 dB up to 145 dB in one hit. Depending on the application, this may not be a killer, but careful design is required.

Linearity is excellent over the quoted measurement range.

Directional characteristics

Measurement microphones are designed to be as omnidirectional as possible, and this depends on the physical dimensions of the capsule being presented to the acoustic field. We are familiar with the difference between free-field and pressure microphones, and we can also choose between sizes of microphone depending on desired frequency range. The MEMS microphone therefore needs to be packaged to simulate the 'normal' characteristics, while allowing for the fact that the sound takes a more tortuous path to the sensor element.

Environmental stability

Early MEMS microphones tended to be sensitive to temperature and humidity, such that a temperature sensor was included to allow

Typical frequency response curve relative to sensitivity at 1KHz

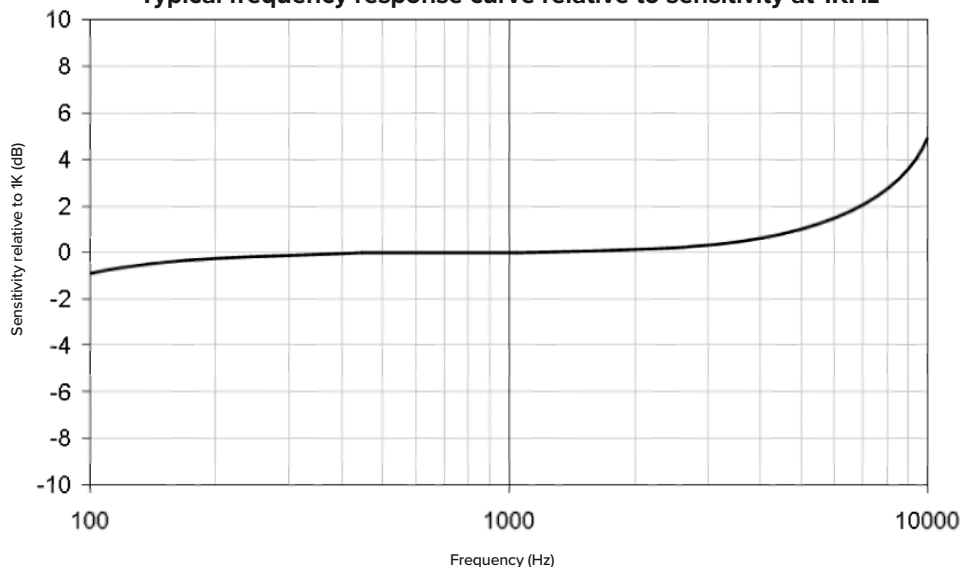

Above: Figure 2: Frequency response of a typical MEMS microphone

corrections to be made. Modern devices are now very stable with temperature and generally require no correction. As with conventional condenser microphones, field of application and packaging (e.g. weather protection) must be considered carefully anyway.

Fields of application

The first application of a MEMS microphone for standardised metrology was in a noise dosimeter², where key requirements were cost and ruggedness. As dosimeters are used for high level measurements, the limitation of the MEMS approach was the upper limit, which needs to be in excess of 140 dB to cover the full requirements of measurements for noise at work. All current MEMS devices are well into distortion at these levels, so it is necessary to design a purely acoustical/mechanical 'pre-attenuator' as part of the packaging, so the MEMS device operates within its linear range.

This has implications for the bottom of the measurement range, but dosimeters are built to the applicable standard, IEC 61252:1993/AMD2:2017, and not the sound level meter standards.

The packaging also includes simulating a 1/2" microphone casing, allowing traditional sound level calibrators to be used.

MEMS microphones are also being used in Smart City and transportation applications³, where the low price allows large sensor arrays to be deployed. In this application, the noise level

variation with time is arguably more important than absolute accuracy, although the networks can be 'calibrated' by the use of a higher cost reference system. Again, statistical analysis of any variation with time can allow corrections to be applied in post-processing, or to alert to any faults or failures.

Again, the typical measurement range of these applications is mostly within the capability of a good quality MEMS device, which may have a noise floor approaching 30 dBA.

MEMS microphones are now being used in conjunction with traditional microphones, not for primary measurement, which is done by the condenser microphone, but to augment the measurement with other data, such as direction⁴. By positioning an array of sensors around an outdoor microphone, the source of noise may be determined both laterally and vertically.

And lastly, MEMS microphones are now being introduced into primary noise measurements⁵, traditionally the domain of condenser microphones. For outdoor measurements, the noise floor is often a limitation, but by using more than one MEMS device, it is possible to reduce the noise component (by averaging the output of two microphones, the noise floor is reduced by nominally 3 dB, for four microphones by 6 dB, etc). By having multiple microphones, an element of redundancy is introduced, allowing continuous monitoring even in the event of a sensor failure. [P50](#)



UKAS Accredited Calibration Laboratory
Visit www.ukas.com for full scope



WE CALIBRATE:

- Sound Level Meters
- Sound Calibrators & Pistonphones
- Microphones
- Octave/Third-Octave Filters
- Accelerometers*
- Vibration Meters*
- Tapping Machines
- Reverberation Time



A FOCUS ON:

- ✓ Fast Turnaround
- ✓ Competitive Pricing
- ✓ Customer Service

"We are very pleased with the excellent service we received from ANV in recent months. Most notably, they provided an efficient and hassle-free calibration service with which we couldn't have been more satisfied."

Jack Richardson, Hilson Moran Partnership Ltd

* Not accredited by UKAS

☎ 01908 642846 | ✉ INFO@NOISE-AND-VIBRATION.CO.UK | 🌐 WWW.NOISE-AND-VIBRATION.CO.UK

Design great spaces with the complete software solution for room acoustics

Try ODEON 16
www.odeon.dk

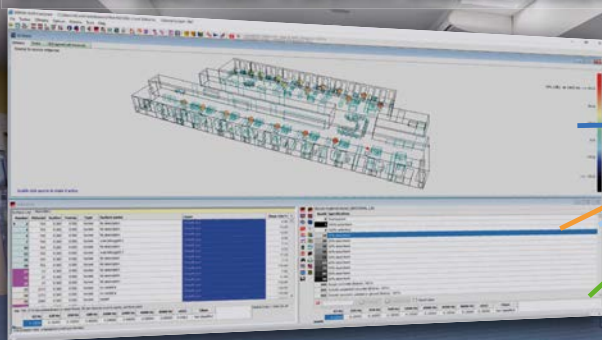

Version 16 released with attractive features:

- Improved sweep-measurement tool.
- Support for ambisonic measurements.
- Hedgehog graphs and other visualisation tools.
- Source to source matrix calculations.
- Materials archive in the Material List.

Available as: Basics, Industrial, Auditorium & Combined



The packaging can be devised such that each microphone ‘unit’ is a self-contained transducer, with a known output independent of each microphone, making it much easier to replace in the event of damage.

Cost

The use of DSP and multiple sensors adds cost to the final result, such that the main benefit of a MEMS sensor, namely price, is seriously eroded. Therefore, we have to consider the additional benefits that the MEMS approach brings such as ruggedness, redundancy and replaceability. After all, there’s not much point in using MEMS for the sake of it, if a condenser microphone will do the job just as well, if not better, at the same price!

Condenser microphones will continue to hold sway for measurements of extremely high or low levels, or for extremes in frequency.

However, for less demanding applications and for wide area IOT measurement arrays, MEMS technology has irresistible advantages.

Calibration

Of course, no measurement is valid without some sort of calibration, either in the field or back in the laboratory.

Field calibration is relatively easily addressed by packaging the MEMS into a traditional ½” format,

so a sound level calibrator can be used, with documented corrections.

In the calibration laboratory, it may be a different matter, as the sound level meter standard IEC 61672:2013 Part 3 involves testing of both acoustical and electrical responses of the meter. If the MEMS part of the microphone is a closed digital circuit, how do we isolate the electrical part of the circuit? The use of a specialised connector is required, to allow the signal to be injected into the analogue part of the circuit (see Figure 1), so the DSP part can be measured in the conventional way. Perhaps the standards will evolve in the future to make this easier, but there’s always the fall-back of doing everything acoustically in an anechoic chamber!

Answer the question!

Going back to the original question posed; ‘Do you think we’ll ever see calibratable MEMS type chip mics capable of replacing half inch mics?’. The answer, (taken from ‘Down With Skool’

by Ronald Searle) *as any fule kno* is yes and no.

Yes, MEMS microphones are already replacing traditional condenser types in noise dosimetry and environmental noise measurements. MEMS technology also brings other toys to the party, such as directional information and wide array measurement.

However, when it comes to replacing a typical IEPE microphone set for general purpose measurements, perhaps in automotive or aerospace applications, this may take a while, the reason being that there is no compatibility with existing front ends or power supplies. IEPE is an almost uniform power supply format for multichannel systems, so a MEMS transducer would have to comply with that, rather than the other way round.

But it’s not beyond the wit of man to come up with something that looks very much like a ½” microphone set, but has a digital output which could be fed to a widely compatible front end, like I2S or SP/DIF. ☺

Below:
A MEMS transducer incorporated into an outdoor monitoring station – note the digital plug-in connector from the microphone ‘package’

About the author:

This article was produced and edited by **John Shelton of AcSoft Group**, with input and help from **Martin Williams of Cirrus Research** and **Ben Piper of Acoustic Sensor Networks**, which is gratefully acknowledged. For further information on measurement techniques, please check out the past Instrumentation Corner articles which you can find by logging into the Group pages of the IOA website. www.ioa.org.uk



References

- 1 ‘Applicability of MEMS microphones for environmental sound level monitoring’, James Oatley, Cirrus Research plc, Internoise 2021, Washington 1-5 August 2021
- 2 <https://svantek.com/products/sv-104a-personal-noise-dosimeter/>
- 3 <http://www.acousticsensornetworks.co.uk/>
- 4 <https://youtu.be/2G6eAuxIOhg>
- 5 <https://svantek.com/products/sv-307a-noise-monitoring-station/>



WHISPER® ACOUSTIC PANELS

For Class A sound absorption in challenging environments, acoustic engineers recommend Whisper®.

Whisper® Acoustic Panels are a honeycomb-like matrix of networked closed cells which efficiently absorb sound.

Why Choose Whisper®?

Unlike conventional fibre, polyester or open cell foams, Whisper® combines several performance attributes into one material:

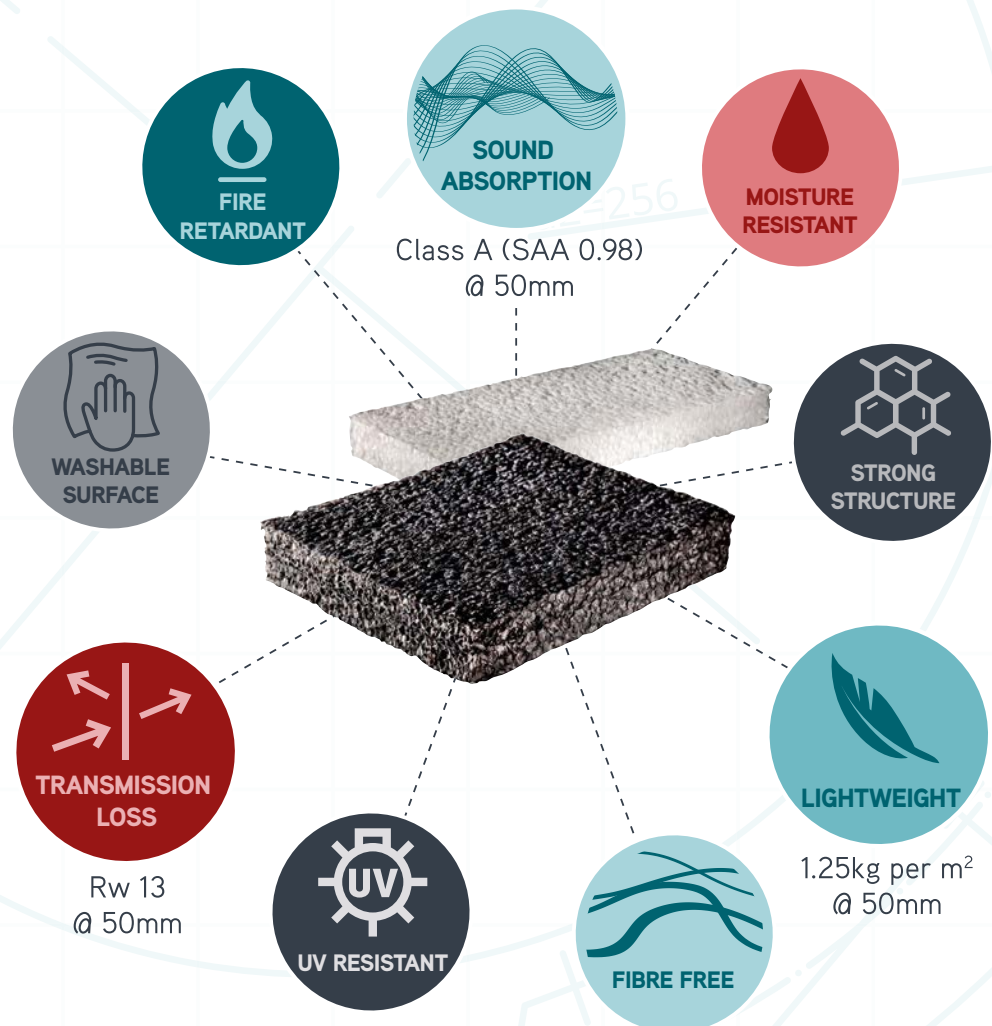

Whisper® Acoustic Panels are suitable for either indoor, or outdoor installations, and have been proven in projects across the world: from restaurants in Italy, to swimming pools in Australia and high-speed rail noise barrier walls in Germany.

NOISE CAN BE ANNOYING...JUST MAKE IT WHISPER®

Find out more about Whisper® Acoustic Panels

pages.sealedair.com/uk-whisper



Introducing our brand new building acoustics kit

I have been working in the building acoustics and building compliance sector for around six years now, selling noise testing equipment and software to users that take the tests all day, every day.

By Aidan Hubbard, Sales Director at AcSoft Ltd



Everybody tells me the same thing: “We need some kit that works together as a set and that is reliable and gets me to the result as fast as possible.”

Most sound level meters will ask users to take a test in every room and at different points repeatedly, it will then take the average reading and provide some results. The equipment has to be taken back to base, plugged into a laptop and run through some software for a complete result. Users then need to have the result signed off and uploaded to the accrediting body. After all of this and maybe a few hours later, invoices can be sent to the customer and testers wait to be paid.

At AcSoft and Svantek UK, we spoke to our customers to find out what they feel is wrong with this traditional method, and this allowed us to figure out exactly what our users want to allow them to work more efficiently.

We established that by saving time, it would allow for more tests to be made and for the tester to be more efficient, more successful and more competitive.

The Svantek Building Acoustics Assistant application does exactly this; the sound level meter will automatically connect to the tester's phone or tablet and will guide them step-by-step into each test. It prevents mistakes by sounding alarms to erroneous or suspect data.

At the end of the test, users can generate a certified certificate and see the test results. Testers will be able to sign it off on site or send it to colleagues for double checking so the job will be completed there and then. No need for post processing, users can simply move onto the next job and continue with their day.

This technique has changed the way people think about equipment required for testing, for example, the SITMA scheme requires the users to upload binary files from the test, up and onto the portal for double checking. Through the Building Acoustics app, users can directly upload files from their phone immediately after the test. This is ground-breaking and has allowed us to be very successful with SITMA users.

New sound level meter

The ground-breaking methodology doesn't stop here, we have now released a new sound level meter, the Svantek 971A, that fulfils the next requirement from the testers, making the kit more affordable. The SV 971A is packed full of specification and directly connects to the Building Acoustics app but at a much lower price! The unique feature of this meter is that it goes even further by making the user potentially more efficient with time-saving techniques. We can use two sound level meters side-by-side in single test, meaning that we can potentially cut the time of the test in half again. We already offer the fastest way to get to results, but this method takes it to another level.

When we launched the dual meter package, testers initially thought that this would be a very expensive way of testing. Rest assured, the price for two meters is almost the same as one meter from our competitors. This method will also allow companies to have two testers out at the same time on different sites. The flexibility of having two meters in this industry is invaluable.

We are dedicated to streamlining processes, reducing costs and allowing testers to be more efficient and competitive. Every new release from AcSoft and Svantek illustrates this effort; our technical support team and application engineers are committed to supporting you on site. 



To find out more about our building acoustics kits:

Email: sales@acsoft.co.uk

Tel: 01234 639550

www.acsoft.co.uk

Exposure to a wider variety of projects?

Greater career prospects?

A greater range of duties and responsibilities?

What are you looking for in your Acoustics career?

Or is it a wider range of duties and responsibilities?

Whatever the reason, Penguin Recruitment are here to help!

Penguin Recruitment is a multi-disciplined Engineering and Environmental Recruitment Consultancy established in 2004. We offer nationwide and international job opportunities for anyone looking to kick start or develop their profession.

With extensive knowledge in the Acoustics and Air Quality Industry, we are proud to offer an energetic can-do approach whilst providing a friendly, professional and knowledgeable service at all times.

If you're a growing business looking to access a wider pool of candidates to help with your expansion plans, then please get in touch!

Penguin Recruitment advertise on more job boards than any other specialist recruitment agency within the acoustics industry, and have a well-established and expansive network of candidates accumulated over 16 years of service, allowing us to provide leading advice on the current candidate market.

For more information please contact Amir Gharaati or Charlotte Lavender on **01792 365000**, or email amir.gharaati@penguinrecruitment.co.uk and charlotte.lavender@penguinrecruitment.co.uk

PENGUIN
RECRUITMENT



www.penguinrecruitment.co.uk

Development of a new ISO Technical Specification on non-acoustic factors to improve the interpretation of socio-acoustic surveys

The following article is taken from a paper, by the authors of this article, presented at the 13th International Commission on Biological Effects of Noise (ICBEN) Congress on Noise as a Public Health Problem, on 14-17 June 2021. The paper is kindly reproduced with permission from ICBEN.

By Benjamin Fenech, Lisa Lavia, Georgia Rodgers and Hilary Notley

The work presented is the result of a programme to develop an international standard series on non-acoustic factors to improve the interpretation of socio-acoustic surveys, which falls under ISO/TC 43/SC 1/WG62 (WG62). The following article sets out the case for support to develop the standard.

The convener of WG62 is Phil Dunbavin, and he is also convener of ISO TC43/SC1/WG54 (WG54) on soundscape. The project manager for the new work item is Benjamin Fenech from the UK Health Security Agency (UKHSA) and a member of WG62. The draft proposal for the new standard was conceived and has been developed

by Benjamin Fenech, Lisa Lavia from the Noise Abatement Society and a member of WG62 and WG54, Georgia Rodgers from UKHSA and a member of WG62 and Hilary Notley from Defra and a member of WG62. Jian Kang and Francesco Aletta, both from University College London and members of WG54, have joined WG62 and will be



part of the development team going forward.

In the UK, this work item sits within the BSI Committee EH/1/3 Residential and Industrial Noise and will also be reviewed by the committee members. The authors welcome further comments on this proposal and expressions of interest to support its development.

Introduction

Many countries already have regulations in place concerning the acceptability of environmental noise exposure, while others are likely to do so in the future. Such regulations often take into account relationships between noise exposure and noise-induced health outcomes, including long-term annoyance and sleep disturbance.

International standards have been developed for the measurement of certain characteristics of environmental sound. Two examples are ISO 1996-1:2016¹, which contains detailed specifications about basic quantities and procedures, measurement of sound, and guidance on the application of these data to set noise limits; and ISO 20906:2009², which specifies criteria for unattended monitoring of aircraft sound in the vicinity of airports.

Other standards focus on the effects of sound on humans. Long-term annoyance is an important health effect attributable to environmental noise, both as a health outcome in its own right, but also as a potential risk factor to other clinical health outcomes³. ISO/TS 15666⁴ provides a standardised specification for the assessment of noise annoyance by social and socio-acoustic surveys. This standard has enabled a more robust consolidation of the international evidence on noise annoyance, by ensuring

consistency in the definition and measurement of this specific health endpoint³.

It is generally accepted that annoyance reactions to environmental noise are determined partly by the acoustical characteristics of the stimulus, and partly by individual, situational and environmental factors (often referred to as non-acoustic factors)⁵⁻⁸.

Non-acoustic factors are estimated to account for up to one third of the variance observed in annoyance reactions⁵ and therefore offer significant opportunities in:

- a) understanding the drivers of annoyance; and
- b) opening up new possibilities for reducing the health burden attributable to noise annoyance.

These opportunities are envisaged to be also applicable to self-reported sleep disturbance. In business terminology, non-acoustic factors have the potential to significantly increase the return on investment in noise effects investigation and mitigation. The World Health Organization (WHO) Environmental Noise Guidelines 2018 acknowledge the important contribution of non-acoustic factors, and recommend that:

“Future intervention studies should use validated and, where possible, harmonized measures of exposure and outcome, as well as of moderators and confounders. ... Further, they should use measures of moderators and confounders, including repeated measurements of situational and personal variables such as activity interference, potential confounders such as noise sensitivity, coping strategies and a range of other attitudinal variables.”⁹

In recent years there has also been a growing interest in the soundscape approach (in line with

the development of the ISO 12913 Soundscape standard series¹⁰⁻¹², with an emphasis on how sound in an environment is experienced by a person and/or people in context. According to ISO 12913-1:2014 assessing soundscape in context includes:

“...the interrelationships between person and activity and place, in space and time... [and] context may influence soundscape through (1) the auditory sensation, (2) the interpretation of the auditory sensation, and (3) the responses to the acoustic environment.”¹⁰

Therefore identifying, measuring and assessing non-acoustic factors is central to measuring and assessing soundscape in accordance with the soundscape standards.

Despite the key role that non-acoustic factors play in both the ‘traditional’ health protection (noise control) and health promotion/improvement (soundscape enhancement) approaches, to date, there is no standardised specification for the assessment of non-acoustic factors in social surveys. For example, the definition and standardisation of non-acoustic factors fall outside the scope of ISO/TS 15666:2021⁴. This means that the extent to which non-acoustic factors are investigated in a particular study is limited by the specialist expertise within the study group, and different studies tend to develop project-specific survey instruments. A standardised approach to non-acoustic factors can offer significant benefits in:

- a) improving the quality, reliability and consistency of the survey instruments; and
- b) enabling data that can be consolidated across projects, thereby strengthening the evidence base and ultimately leading to a better understanding

P56

References

- 1 ISO 1996-1:2016 Acoustics — Description, measurement and assessment of environmental noise — Part 1: Basic quantities and assessment procedures.
- 2 ISO 20906:2009 Acoustics — Unattended monitoring of aircraft sound in the vicinity of airports.
- 3 Guski, R., Schreckenber, D., & Schuemer, R. (2017). WHO Environmental Noise Guidelines for the European Region: A Systematic Review on Environmental Noise and Annoyance. Int J Environ Res Public Health, 14(12). Retrieved from <https://www.ncbi.nlm.nih.gov/pubmed/29292769>
- 4 ISO/TS 15666:2021 Acoustics — Assessment of noise annoyance by means of social and socio-acoustic surveys.
- 5 Guski, R. (1999). Personal and social variables as co-determinants of noise annoyance. Noise & Health, 1(3), 45-56.
- 6 Gjestland, T. (2019). Aircraft noise annoyance non-acoustic factors. ICAO Environmental Symposium. Retrieved from <https://www.icao.int/Meetings/ENVSymposium/Presentations/Truls%20Gjestland%20Session%204.pdf>
- 7 Flindell, I. H., & Witter, I. J. (1999). Non-acoustical factors in noise management at Heathrow Airport. Noise and Health, 1(3), 27.
- 8 Fields, J. M. (1993). Effect of personal and situational variables on noise annoyance in residential areas. The Journal of the Acoustical Society of America, 93(5), 2753-2763.
- 9 World Health Organisation. (2018). Environmental Noise Guidelines for the European Region.
- 10 ISO 12913-1:2014 Acoustics — Soundscape — Part 1: Definition and conceptual framework.
- 11 ISO/TS 12913-2:2018 Acoustics — Soundscape — Part 2: Data collection and reporting requirements.
- 12 ISO/TS 12913-3:2019 Acoustics — Soundscape — Part 3: Data analysis.

and application of non-acoustic factors to improve the health and quality of life of citizens across the globe.

On behalf of the British Standards Institution (BSI), the authors of this paper have been tasked with drafting an outline scope for a new International Technical Specification (ISO/TS) on non-acoustic factors. This paper describes the progress to date. The content of this paper includes valuable contributions received from a panel of external experts that was informally consulted in 2020 – see Acknowledgements.

Proposed aim and scope

Definition of non-acoustic factors

There does not appear to be a single consensus definition of the term ‘non-acoustic factors’ in the literature. The first aim of the ISO/TS, therefore, would be to set out a standard definition for the term that can be widely agreed upon. Some examples of definitions or descriptions of non-acoustic factors in the literature include the following:

- a) ‘all those factors other than noise level alone which contribute to noise annoyance and similar effects’⁷
- b) ‘moderating variables, i.e. personal and social aspects of the residents’⁵
- c) ‘differences in auditory processing of those cues (e.g. spectral-shape sensitivity)’¹³
- d) ‘by convention: all non-DNL factors’ (DNL= day-night average sound level in dB)⁶
- e) ‘all those factors other than noise level which contribute to annoyance’¹⁴.

Therefore, at present, there is a wide range of interpretation of the term, ranging from everything apart from the long-term average noise level [d]; to only ‘moderating variables’ i.e. personal and social aspects of the residents [b]. The

following extract, from a document published by a campaign group from the UK, highlights some of the complexities that can arise as a result of this ambiguity:

“In literature the level of background noise, the so-called ambient noise, is considered both an acoustic factor and a non-acoustic factor. This implicates that authors disagree in which category ambient noise belongs. Kroesen (2006) clearly identifies background noise as an acoustic factor. Background noise is after all a sound. On the other hand, Sanchez et al. (2015), classified ambient noise as a non-acoustic factor. They divide non-acoustic factors into personal, social and situational factors. The latter refers to characteristics in which the noise event takes place. Background noise is therefore not the sound event itself, but a non-acoustic situational factor.”¹⁵

Therefore, a key aim for the new TS is to achieve consensus on a clear definition for the term ‘non-acoustic factors’.

From initial conversations with a small number of experts there was agreement that physical acoustic quantities should not be considered as non-acoustic factors. Therefore, averaged sound level (L_{eq} -based metrics, L_{den} , L_{dn} , L_{night}), maximum/peak sound level, number of events exceeding a set threshold (N_{xx}), amplitude modulation (for wind turbine noise), outdoor to indoor sound attenuation and background sound level should be considered as ‘acoustic factors’.

There are other objective quantities that are strongly related to acoustic parameters, such as number of vehicle pass-bys/flyovers, height of the noise source (with respect to aircraft flyovers), and duration of respite (predictable periods of relief from noise from a specific source) that are likely to lead to some debate as to whether they can be categorised as acoustic or non-acoustic.

It is also recognised that some factors can have both acoustic and non-acoustic components; e.g. background/ambient sound can be described both in terms of acoustic quantities (such as the L_{90} percentile), and with semantic descriptors such as ‘eventful/uneventful’ or ‘tranquil/chaotic’.

A tentative definition for non-acoustic factors may be:

“All factors other than the objective, measured or modelled acoustic parameters which influence the process of perceiving, experiencing and/or understanding an acoustic environment in context, without being part of the causal chain of this process.”

We anticipate a healthy debate and further refinement of this proposed definition, particularly on the last phrase, for example, on whether certain non-acoustic factors can function both as moderator and mediator variables¹⁶.

Scope of the Technical Specification

It is proposed to publish this standard as an ISO/TS because, according to the International Organization for Standardization, a TS: “...addresses work still under technical development, or where it is believed that there will be a future, but not immediate, possibility of agreement on an International Standard...[While] a TS can be published for immediate use... it also provides a means to obtain feedback.”¹⁷

The feedback period is important because the review period for a ISO/TS is shorter than that of a full standard (i.e. three years for a TS versus five years for an International Standard)¹⁸.

ISO recommends that a Technical Specification has a maximum life of six years, after which it would, ideally, progress to be transformed to an International Standard. While this is not a strict rule, it is a good indicator of the use and development of the specific

References

- 13 Majdak, P., Baumgartner, R., & Laback, B. (2014). Acoustic and non-acoustic factors in modeling listener-specific performance of sagittal-plane sound localization. *Frontiers in psychology*, 5, 319.
- 14 Civil Aviation Authority. (2018). CAP 1588: Aircraft Noise and Annoyance Recent findings.
- 15 Ummels, R. E., K. (2016). Ambient Noise. Gatwick Area Conservation Campaign, Gatwick in Perspective, 1.
- 16 Baron, R. M., & Kenny, D. A. (1986). The moderator–mediator variable distinction in social psychological research: Conceptual, strategic, and statistical considerations. *Journal of personality and social psychology*, 51(6), 1173.
- 17 ISO. Retrieved from <https://www.iso.org/deliverables-all.html>
- 18 ISO. Guidance on the Systematic Review Process in ISO. Retrieved from <https://www.iso.org/files/live/sites/isoorg/files/store/en/PUB100413.pdf>



area under review. As research regarding non-acoustic factors is rapidly evolving, the relative flexibility of a TS is apposite.

This TS would sit at the interface of the traditional noise control and soundscape approaches and can be seen as complimentary to ISO/TS15666 and the ISO 12913 series. We recommend that this TS should have a specific focus on those non-acoustic factors that will help aid understanding the effects of noise and soundscape assessments in relation to health and quality of life. Therefore, the scope of this TS would cover the collection, analysis and interpretation of non-acoustic factors in all environments, both indoor and outdoor, in any context.

This could include:

- socio-acoustic surveys investigating noise annoyance and self-reported sleep disturbance at home. 'Home' includes both the indoor space and any external amenity space that forms part of the dwelling (such as balconies, gardens and any shared private amenity space);

- soundscape assessments of general living and recreational environments, including indoor and outdoor urban, suburban, peri-urban and rural areas; and
- work settings.

It is envisaged that procedural aspects that are required to ensure high-quality social surveys, which are not specific to social surveys on noise (such as sampling methods), would fall outside the scope of this Technical Specification. Age, gender, education, socio-economic status are considered to be important non-acoustic factors. However, questions on these attributes tend to follow national and/or sector-specific methodologies (whether in government, academia, industry or practice) and, therefore, are expected to fall outside the scope of the TS, albeit they are important and necessary data to collect.

There are additional specific details on the scope that need to be discussed and agreed early on in the development of the Technical Specification. For example, whether it would be applicable to surveys of all ages, or only for adult groups,

and if it would be relevant to all sources of sound, as is inherent to a soundscape approach (e.g. transport, wind turbines, industry, construction, building services equipment, neighbours, nature, etc.).

An International Standard/TS may include both normative and informative references/content. For this TS the normative content could include:

- a list of non-acoustic factors that should be included as a minimum in socio-acoustic surveys;
- if consensus can be achieved, exact wording / survey instruments to measure specific non-acoustic factors; and
- if consensus can be achieved, methods for data analysis and interpretation.

Informative content could include:

- additional non-acoustic factors that may be included, depending on survey/study objective;
- examples of wording to measure non-acoustic factors (when consensus cannot be reached on a single method); and
- examples of methods for data analysis and interpretation. P58

This TS, and the data it helps generate is expected to provide significant added value to acousticians, planners, designers, researchers, psychologists, sociologists, epidemiologists, environmental and public health practitioners interested in:

- the appraisal of a sound environment in context;
- soundscape appraisal when applying the ISO soundscape standard series;
- moderators of sound impacts – health pathway;
- policy development;
- improving the accuracy of environmental noise and health impact assessments; and
- designing interventions to enhance the soundscape and improve health outcomes.

Proposed structure

Due to the complexity of the subject area, and the likely need to engage different experts across multiple disciplines at different stages, the proposed standard can be broken down into several parts.

Our preferred approach would be for the ISO/TS to follow the ISO 12913 Soundscape standard series structure, i.e. divided into the following parts:

- Part 1 – Definition and conceptual framework;
- Part 2 – Data collection and reporting (including standardised questions);
- Part 3 – Data analysis;
- Part 4 – Interpretation.

Part 1 would set out an overarching definition of non-acoustic factors (as discussed in the previous section), a conceptual framework and a categorisation framework.

Conceptual framework and categorisation

Defining a conceptual framework in Part I of the TS would help with contextualising future discussions. The following figure is a slightly amended version of Figure 1 in ISO 12913-1:2014, and can form a starting point for discussion. **PGO**

“Long-term annoyance is an important health effect attributable to environmental noise, both as a health outcome in its own right, but also as a potential risk factor to other clinical health outcomes”

Below: Figure 1: Influence of non-acoustic factors on the interpretation of auditory stimulus – a conceptual diagram adapted from ISO 12913-1:2014.¹⁰

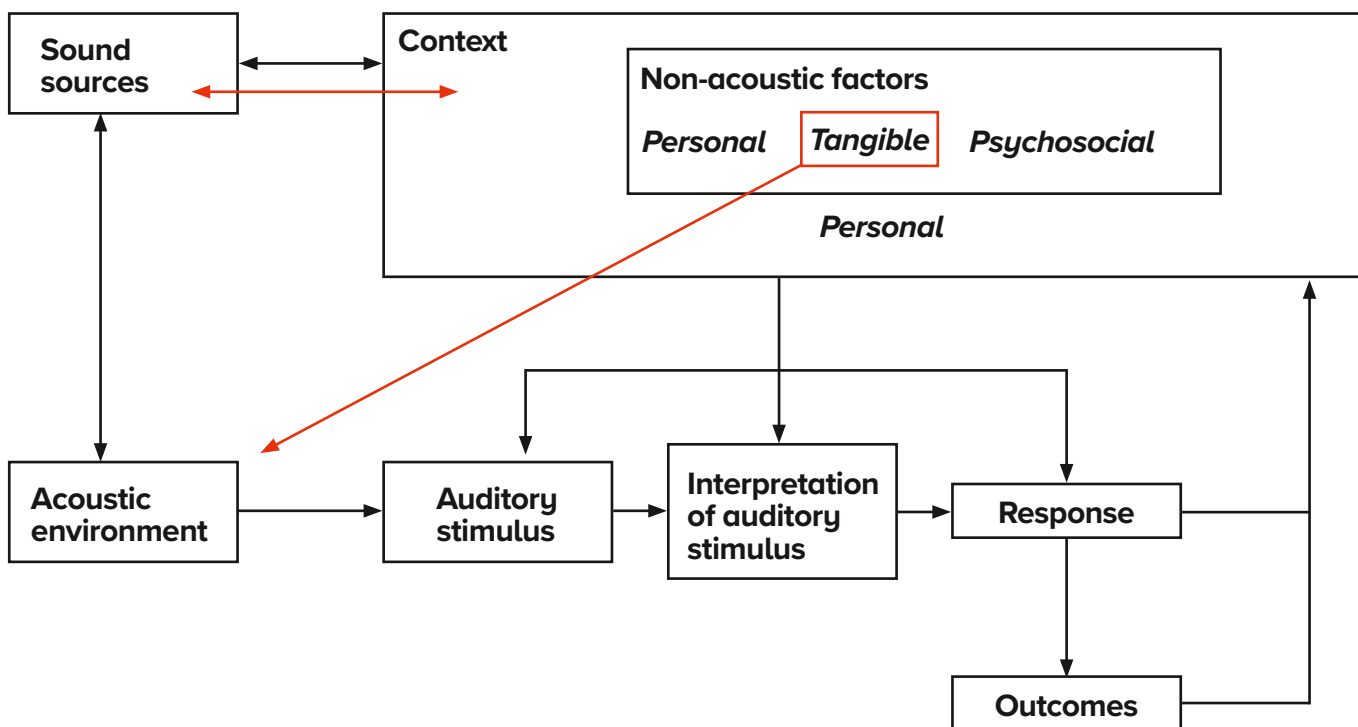

References

¹⁰ ISO 12913-1:2014 Acoustics — Soundscape — Part 1: Definition and conceptual framework.



SCAN ME FOR DEMO KIT REQUEST

Manufacturing solutions for architectural acoustics and vibration problems since 1969.

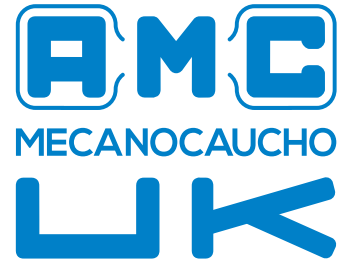

AMC DEMO KITS

TOOLS TO PROVIDE ACOUSTICIANS WITH CONFIDENCE WHEN SPECIFYING PRODUCTS FOR COMPLEX INSTALLATIONS



AMC MECANOCAUCHO HAS DEVELOPED AN AKUSTIK FLOOR MOUNT TEST PLATFORM TO ENABLE IMPACT NOISE MEASUREMENTS IN SITU

This portable test platform simulates the installation of the Akustik Floor Mounts, it has dimensions of 50x50cm and a weight of 20Kg.

This test platform is ideal for acoustic engineers that want to make an impact noise test in situ inside a building. This test can be carried out in an old building which requires renovation or even in a new building which is partly constructed. The improvement in impact noise isolation than can be gained from AMC Mecanocaucho acoustic floor mounts can be easily demonstrated.

Scan me for additional info.



AKUSTIK + SYLOMER® AKUSTIK FIT

The AMC-MECANOCAUCHO® anti vibration mounts have been designed for the insulation of gymnasium equipment.

TECHNICAL CHARACTERISTICS

- Easy to install.
- Maintenance free.
- Adjustable stiffness.

APPLICATIONS

- Treadmills.
- Bodybuilding equipment.
- Other gymnasium equipment can be consulted.



Scan me for additional info.

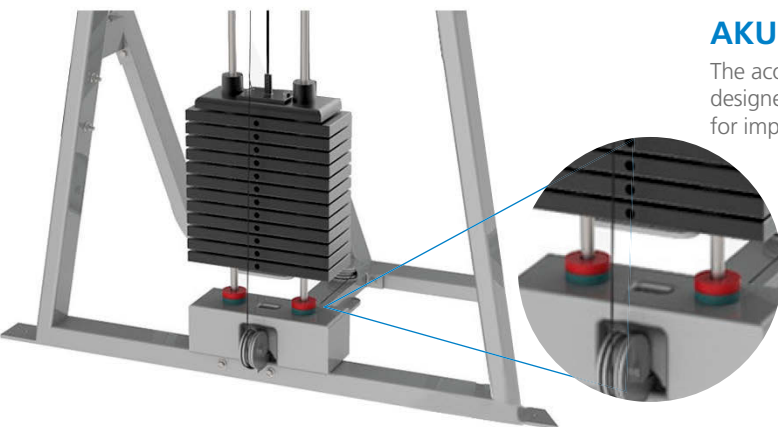

AKUSTIK + SYLOMER® MPR + SYLOMER®

The acoustic washer anti vibration mounts have been designed for the insulation of gymnasium equipment. Mainly for impact insulation of weight stacks or weight plates.



Scan me for additional info.



Bipin J Mistry
158 Kedleston Road, Leicester,
Leicestershire, LE5 5BL

+44 07711 349 425
+44 0116 2219659
 bjmistry@amc-ui.co.uk
 www.mecanocaucho.com
www.akustik.com

Lewis Metcalf
27 Blackfriars Road, Syston,
Leicester LE7 2DS

+44 (0) 7523 118 007
 lmetcalf@amcsa.es
 www.mecanocaucho.com
www.akustik.com



There is a considerable amount of literature relating to non-acoustic factors (examples can be found in the IC BEN paper by Fenech et al.¹⁹), although, as discussed previously, it is not always cohesive. Drawing on this literature it is possible to tentatively define a number of broad categories of non-acoustic factors. For example, Guski⁵ distinguishes between four categories:

- individual (or personal);
- social;
- situational; and
- environmental.

Riedel²⁰ has proposed three categories:

- personal;
- tangible; and
- psychosocial.

It is worth noting that there may be overlap between such categories, for example between individual and social factors. An agreed set of broad categories of non-acoustic factors will be an important feature of Part I of the proposed TS, along with a non-exhaustive list of examples for each.

As an example, following Riedel's categories, the following factors may be included:

Table 1: Example categories of non-acoustic factors

CATEGORY OF NON-ACOUSTIC FACTOR	ILLUSTRATIVE EXAMPLES
Personal: strongly linked to an individual, show stability over time and situation, vary between individuals.	Noise sensitivity; Coping capacity; Perceived control; Perceived fear.
Tangible: properties of the specific environment.	Access to green space; Quiet façade; Location of inhabited space(s); Visual modifiers.
Psychosocial: shared between individuals of a community.	Perceived fairness; Perceived community benefit/disbenefit; Attitude towards noise authorities.

References

- 5 Guski, R. (1999). Personal and social variables as co-determinants of noise annoyance. *Noise & Health*, 1(3), 45-56.
- 19 Fenech, B., Lavia, L., Rodgers G., Notley, H. (2021) Development of a new ISO Technical Specification on non-acoustic factors to improve the interpretation of socio-acoustic surveys. In Proceedings to the 13th IC BEN Congress on Noise as a Public Health Problem.
- 20 Riedel, N., Van Kamp, I., Köckler, H., Scheiner, J., Loerbroks, A., Claßen, T., & Bolte, G. (2017). Cognitive-motivational determinants of residents' civic engagement and health (inequities) in the context of noise action planning: A conceptual model. *International journal of environmental research and public health*, 14(6), 578.

Conclusion

A new multi-part ISO Technical Standard is proposed to formalise the assessment of non-acoustic factors relevant to the effects of noise and soundscape assessment in relation to health and quality of life. Such a standard, and the data it would help generate, are expected to offer significant added value to acousticians, planners, designers, researchers, psychologists, sociologists, epidemiologists and environmental and public health practitioners interested in the relationships between sound and health and quality of life. The development of the TS is at the initial stages, and this paper provides an overview of potential scope, definitions and conceptual framework.

Acknowledgements

The authors would like to acknowledge valuable comments received during the development of the new work item proposal for a standard on non-acoustic factors by Rainer Guski, Irene van Kamp, Dirk Schreckenberg and Natalie Riedel on the definition, scope, conceptual framework and non-acoustic factor categories. The authors would also like to thank the ICBEN committee for their kind permission to reprint this article from the conference proceedings of ICBEN 2021 [19]. ©

“There are additional specific details on the scope that need to be discussed and agreed early on in the development of the Technical Specification. For example, whether it would be applicable to surveys of all ages, or only for adult groups, and if it would be relevant to all sources of sound, as is inherent to a soundscape approach (e.g. transport, wind turbines, industry, construction, building services equipment, neighbours, nature, etc.)”



Acoustics in action photoshoot by London South Bank University

As part of the IOA initiative to own a large and diverse stock of images for its media communications and promotional purposes, London South Bank University (LSBU) has kindly donated 865 photos to contribute to that stock.



A photoshoot was organised and led by IOA Diploma course director at LSBU, Luis Gomez-Agustina, to provide relevant and attractive images that represent and illustrate the acoustics profession in action. Six students on the current 2021-22 Diploma course kindly assisted by composing, taking and featuring in the photos.

The images were captured on 14 October 2021 with a professional camera at diverse and representative locations. The session was constrained by a tight schedule of a natural daylight time window spanning one lunch break and two hours after lectures.

The images show modern and diverse young acoustic professionals at work. The participating students and course director really enjoyed the experience and commented on the unexpected new skills learned.

The IOA is grateful to the six LSBU Diploma students: Ravee Long, Grame Hales, Nilav Babariya, Yaa Agyare, Leonardo Fernandez, Steve Pilotti and course director, Luis Gomez-Agustina, for their generous contribution.

It is hoped that this example will encourage other members to also provide images to add to the IOA media database. And if you plan to take images/media representing the acoustics profession in action and donate them to IOA please email ioa@ioa.org.uk for guidance.

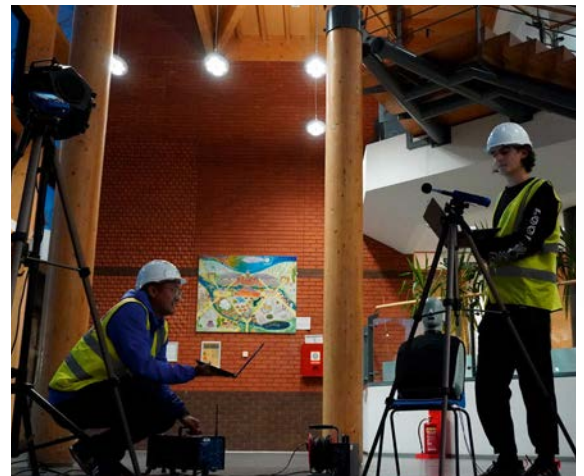
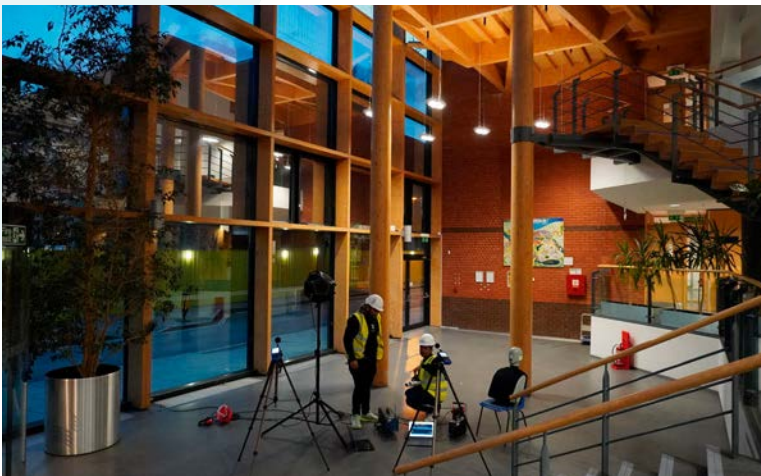

All participants in the photo shoot are shown in the group photo in the LSBU anechoic chamber. They are: Back row L-R: Nilav Babariya, Luis Gomez-Agustina, Yaa Agyare, Leonardo Fernandez and Ravee Long. Front row L-R: Steve Pilotti and Graeme Hales

ENVIRONMENTAL SOUND GROUP

Environmental Sound Group Committee Nominations

By Steve Mitchell, Chair, Environmental Sound Group

The IOA's old Environmental Noise Group is now known as the Environmental Sound Group, as discussed in Graham Parry's article in the November/December 2021 issue of Acoustics Bulletin on pages 63-65.

The change in name reflects a widening of the group's remit to include positive aspects of environmental sound and soundscapes. As chair of the Environmental Sound Group, I see this as an opportunity to reinvigorate the group, and expand our activities into this important area.

To help the Committee understand the issues and steer the group in the right direction I would like to invite IOA members with experience and enthusiasm for soundscape assessment to join the committee.

Please send details of how you can help to me by 25 February 2022, and the committee will review the nominations.

Email: Steve@MitchellEnvironmental.co.uk

MEASUREMENT AND INSTRUMENTATION GROUP

Chairman's annual report

By John Shelton, Chair, Measurement and Instrumentation Group

During 2020/2021, the Group has organised one, one-day meeting, and produced six articles for Acoustics Bulletin.

The one-day meeting was held via Zoom in June 2021 using a new format called 'Ask the Expert'. Designed as a forum for members to ask burning questions about sound and vibration instrumentation, more than 70 members registered, making for a lively session. Chaired by Simon Bull, the panel included Mark Dowie, Martin Armstrong and Tony Higgins, to whom I send my thanks. The outcome of the meeting was reported in the November/December 2021 issue of Acoustics Bulletin and a key question on MEMS microphones has generated a new Instrumentation Corner article for the January/February 2022 issue.

A follow-up meeting is planned for February 2022, and it is hoped that the format can be developed further.

Over the past year, the Group's committee members have continued to contribute to Instrumentation Corner, the latest being No 73 in the November/December 2021 issue, covering vibration instrumentation and measurement guidance, by Martin Armstrong. Other issues covered:

- measurement of traffic noise during lockdown by Tony Higgins;
- testing of low-cost sound level meters to BS EN 61672 Part 3, by John Campbell and Martin Williams;
- measurement of peak particle velocity by Steven Cawser; and
- health and cost benefits of highways noise barriers by Giles Parker.

All of these papers form a historical reference section, which can be accessed in the M&I Group pages of the IOA website. A full schedule is planned going forward, but we welcome suggestions for future subject matters.

In 2021, one of our founding members and first Chairman, Richard Tyler, stepped down from the committee after more than 20 years' service. It's fair to say that the Group has got where it is today thanks to Richard, and his contributions will be missed.

My thanks go, as ever, to all members of the committee for the active roles they take in all aspects of the Group's activities.

Lastly, I would like to extend my best wishes to our honorary secretary, Sue Dowson, as she recovers from illness, and we look forward to seeing her back in action next year.

Inter-noise 2022 Profession, Training and Outreach session

The IOA Equality, Diversity and Inclusion (EDI) working group has been invited to co-organise the Inter-noise 2022 Profession, Training and Outreach session.



Angela Lamcraft,
Chair of the EDI working group

This session will encompass 'Strategies to increase representation of currently under-represented groups in acoustics and noise control education, training and recruitment; workplace climate and retention; diversity in leadership of technical societies; outreach activities to increase awareness of acoustics and participation in STEM amongst schoolchildren.'

We are currently exploring how we can best present information on this topic.

Possibilities include:

- posters;
- a round table discussion; or
- a paper prepared by the EDI working group with contributions from interested people.

Ideas include examples of:

- best practice;
- lessons learned from strategies that have been implemented; and
- ideas on how EDI can be improved within academia and the industry.

Can you contribute?

We are particularly looking for contributions from people from underrepresented groups such as women; people from minority ethnic backgrounds; people with disabilities, health conditions or who are neurodiverse; people who are non-heterosexual or trans-gender; parents and carers; and people who otherwise consider themselves discriminated against or disadvantaged within acoustics.

Anyone interested in contributing to the session or with ideas about the format of the session can email diversity@ioa.org.uk ©

The deadline for contributions is 21 January 2022.



Sigicom
Vibration
Noise
Geotech

INFRA

A Complete Solution for Construction Site Monitoring

01403 595020 info@sigicom.co.uk www.sigicom.com

NEWS

AES UK committee elected

The Audio Engineering Society (AES) UK Section is proud to announce the new executive committee for the 2021-2022 year, following an online ballot of eligible UK members. The new committee comprises Chair Dr Neil Johnson, Vice Chair Dr Michael Turner, and six committee members: Professor Jamie Angus-Whiteoak, Ahmed Gilby, Stuart Gillan, Dr David Moffat, Susan Parker and Dr Ben Supper.

The new executive committee brings together AES veterans and more recent members. All the committee members are excited to be voted in by the UK members and are looking forward to re-invigorating the AES in the UK. Chairman, Dr Neil Johnson, said: "This is an exciting time, with audio taking a lead role in recent times and online communications affecting everyone's lives.

"The new committee is dedicated to promoting the AES's aims of audio engineering excellence through knowledge sharing, education, networking and standardisation."

The executive committee is aided by six regional groups: Cambridge, London and South East, Midlands, North of England, Scotland, and South and South West. Together with the extensive events and resources available through the global AES organisation, the UK section is planning a programme of both online and physical meetings in the coming months. For further information please email the committee at info@aes-uk.org www.aes-uk.org.uk

Eight step toolkit that gets businesses on the road to net zero carbon

The NetZeroToolkit by Edinburgh Science is a free resource that provides practical support to SMEs starting out, or accelerating, their journey to net zero.

The toolkit breaks carbon management down into eight actionable steps, each focused on reducing emissions in individual business areas. Each step signposts to a carefully selected set of resources.

Completing The NetZeroToolkit allows SMEs to:

- identify the changes that they need to make;
- access a simple directory of resources to help implement them; and
- create an actionable carbon management plan.

This becomes a skeleton reduction strategy and something that can be referred back to when making future decisions. Following the process with futureproof businesses by supporting them to achieve Net Zero carbon emissions by 2040.

www.thenetzerotoolkit.org

NetZeroToolkit



The NVEG Presents

Drone Noise: The next Public Health Challenge?

Dr Antonio J Torija Martinez
THE UNIVERSITY OF SALFORD

Wednesday 9th February 2022
13:00 - 14:00

zoom

FOR MORE INFORMATION:

www.ioa.org.uk/events E: ioa@ioa.org.uk T: +44 (0)300 999 9675
Institute of Acoustics, Silbury Court, 406 Silbury Boulevard, Milton Keynes MK9 2AF

Institute of
Acoustics

Sustainable Acoustics offsets DOUBLE its carbon footprint

Sustainable Acoustics has offset double its carbon footprint for the two financial years April 2020 to April 2022, offsetting a collective total of 68.10 tonnes CO₂e.



As part of the company's approach to take responsibility for its impact on the environment, it has partnered with climate and sustainable development experts, ClimateCare, to offset double its carbon emissions associated with all Scope 1, 2 and 3 carbon emissions, including 100% of Scope 3 emissions generated by staff commuting, business travel, water and waste.

Katherine Howlett, Sustainable Acoustics Sustainability Manager, said: "We chose to offset our carbon emissions to provide the best 'safety net' possible to ensure our emissions are removed safely from the atmosphere and provide the best margin for error in our calculations."

As well as taking actions to reduce their footprint by 50% by 2025 through cutting emissions associated with business travel and commuting with a transition to electric vehicles and a transition towards renewable energy production, unavoidable emissions will be offset through projects including two world-leading clean cooking projects in Bangladesh and Ghana. These clean cooking projects not only cut carbon emissions, helping tackle climate change, they improve lives by halving fuel bills for families and reducing exposure to toxic fumes. By cutting fuel requirements the projects also reduce deforestation, protecting precious habitat.



The 'agent of change' principle

Manchester's Night & Day is fighting for survival following noise complaints from a resident who has moved into a flat close to the music venue. Served with a Noise Abatement Notice, it is being threatened with closure by Manchester City Council (MCC).

In a statement, the venue explained that the new complaints were made by a local resident who moved into the city centre location during lockdown, while Night & Day was closed because of COVID restrictions.

It explains: "As restrictions lifted and life returned to the surrounding Northern Quarter area, we were able to put on our first live music event. The resident visited us next day and has since reported us to MCC. We have met the resident a number of times to explain what we do and that

nothing has changed operationally to how we operated pre-lockdown and the 28 years prior to that".

"We ask for MCC Licensing to remove our Noise Abatement Notice and for the council to address the real issue here, which is that housing with ill-considered planning and construction has been approved and built next to a pre-existing live music business", it goes on. "Over the past 15 years, flats have been built or existing buildings converted to flats around us with no real thought or consideration to the pre-existing business, building and what it does".

In 2018, the UK Government introduced the 'agent of change' principle into planning law, which places the onus on developers to identify and mitigate potential future noise issues.

Acoustically detecting blood oxygen levels

During the 181st Meeting of the Acoustical Society of America, Shashank Sirsi, from the University of Texas at Dallas, discussed how circulating microbubbles can be used to measure oxygen levels in the blood.

Microbubbles are smaller than one hundredth of a millimetre in diameter and can be made by emulsifying lipids or proteins with a gas. The gas filling of microbubbles causes them to oscillate and vibrate when ultrasound is applied, scattering energy and generating an acoustic response that can be detected by a clinical ultrasound scanner. They are routinely used in medical imaging to provide greater contrast in tissue.

Haemoglobin will form a stable shell around microbubbles. It then continues to carry out its typical role of binding and releasing oxygen in blood.

Sirsi and his team developed microbubbles to acoustically detect blood oxygen levels, since the microbubble shells are altered by structural haemoglobin changes in response to oxygen. The haemoglobin shell is continually responsive to oxygen after surrounding the bubble and has been optimised to perform in living organisms' circulation.

"When oxygen binds to haemoglobin, there are structural changes in the protein that change the mechanical properties," said Sirsi. "The mechanical properties of the shell dictate the acoustic response of a bubble, so our hypothesis was that different acoustic responses would be seen as the shell gets stiffer or more elastic."

Preliminary results show a strong correlation between oxygen concentration and the acoustic bubble response, highlighting the potential use of microbubbles as oxygen sensors. This capability would have many benefits for medicine and imaging, including evaluating oxygen-deprived regions of tumours and in the brain.

- Acoustic, Fire, Structural and Physical test laboratory
- Site acoustic pre-completion testing

The Building Test Centre
Fire Acoustics Structures

T: 0115 945 1564

www.btconline.co.uk
btc.testing@saint-gobain.com



eNView, the revolutionary noise and vibration monitoring system

KP Acoustics Group has launched eNView, a user-friendly monitoring solution that combines real-time noise and vibration and dust monitoring equipment into one device, boasting plug and play usability. It's lightweight and compact, measuring just 95mm x 110mm x 225mm and weighing a mere 1.6kg.

Dr Kyriakos Papanagiotou, founder of KP Acoustics Group and the innovator behind eNView, said. "In June 2021 we became the only acoustics consultancy to offer our own research and development capability in-house and now we're launching eNView — the paradigm shift in technology in environmental monitoring."

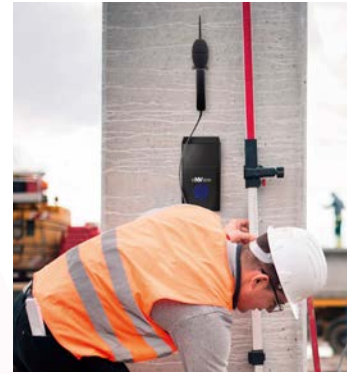

NTi Audio and Casper to equip Swiss army airfields

NTi Audio AG (NTi) and Casper BV (Casper) jointly tendered to provide a complete airport noise and flight tracking monitoring solution for Swiss army airfields and were awarded the project.

Existing airport noise monitoring stations will be replaced and integrated into a modern, local cloud-based solution allowing noise and radar data to be visualised and correlated in real-time. Each nominated airfield will be equipped with approximately 10 monitoring stations, placed at strategic positions around the base. The connected noise and weather monitoring stations will continuously deploy measurement values which will then be analysed in the Casper Noise software. After the installation phase, a 15-year license, support and maintenance contract will be in place.

The mobile or permanent monitoring stations will use the XL2 Sound Level Meter and the M2340 measurement microphone with dedicated outdoor weather protection at their measurement core. The M2340 also features self-verification circuitry, allowing the verification of the uncompromised measurement accuracy since the last calibration.

A micro-controller in each of the noise monitoring terminals manages all components, collects the state-of-health (SOH) information and intelligently organises the measurement data



flow. A 4G/LTE gateway transfers all required data into the cloud, the data is then immediately forwarded over a secure data channel to the proprietary armasuisse servers for further processing and reporting. The described system features several layers of redundancy, making sure that no data is lost in case of power failure or disrupted wireless connections.

Sto System upgrades acoustic environment for London's Raphael Court

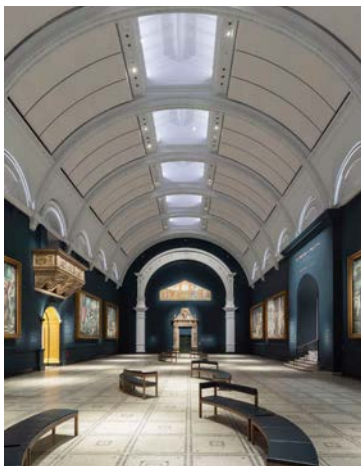

The refurbished Raphael Court at the V&A, 2021 © Victoria and Albert Museum, London

The StoSilent Distance acoustic ceiling and wall system from Sto was specified for the refurbishment of the Raphael Court at the V&A in London and it now creates the perfect acoustic environment for a display of Renaissance art treasures.

"This was a very detailed and complex project to create a new acoustic environment which suited the function of the gallery," explains James Gosling, Sto's Acoustics Project Manager. "Effective acoustic attenuation in the large gallery space was an essential requirement for visitors to enjoy the artworks. The solution was to install a bespoke framework system which would hold 42 curved StoSilent Distance acoustic attenuation panels, each one over 5m long."

When it came to specifying the acoustic system, project architects Feilden Clegg

Bradley Studios were looking for a solution which was lightweight, as they would be adding extra weight to the existing building. It also had to be able to accommodate the different angles and curves of the vaulted ceiling.

"Improving the gallery acoustics was a complex and challenging project," says Robert Austin of authorised Sto applicator, Alpine Finishing. "The priceless artworks measure some 5m x 3.5m, so rather than move them, the decision was made to construct protective shields around them. That allowed them to remain in place during the installation work, but added an extra dimension to the project. The solution had to be adapted as the work progressed and new considerations arose, but the Sto system was sufficiently flexible to accommodate all the necessary changes." ©

'Acoustics in Architectural Design' by Raf Orlowski

Reviewed by Bridget Shield MBE

Raf Orlowski's book is a welcome addition to the literature on architectural acoustics. It provides a comprehensive review of the development of the acoustic design of many different types of building with particular emphasis on spaces for the performing arts such as opera houses, theatres and concert halls.

'Acoustics in Architectural Design' is written in a relaxed, easy to read style with interesting and entertaining anecdotes peppered throughout the text. It is an attractive publication being copiously illustrated with photographs and diagrams and will appeal to students of architecture, music and acoustics, and to professionals working in those disciplines.

The book starts with a brief introduction to some of the acoustic principles and parameters relevant to room acoustics. The remaining chapters each focus on the architecture and acoustic design of a particular building type. Within each chapter, the acoustic requirements of the specific type of building are described and elucidated through many illustrated case studies. These examples are presented in chronological order in each chapter, enabling an appreciation of how certain architectural forms and acoustic design concepts have developed. They also show how it is possible to resolve the sometimes conflicting requirements of architecture, aesthetics and acoustics.

Performance spaces

Over half the book is concerned with the design of performance spaces, tracing the evolution of auditorium design from classical Greek amphitheatres to the present day. There are two chapters on opera houses and concert halls, the first concerning auditoria built pre 20th century. The second

describes those designed in the 20th and 21st centuries, when there was greater understanding of room acoustics following Sabine's studies of reverberation and subsequent research on auditorium acoustics. A chapter on theatre acoustics gives many examples of UK theatres from Elizabethan times to the 21st century. The design of smaller performance spaces as well as rooms required for music teaching is discussed in a chapter on music schools and small recital halls, again illustrated with many 20th and 21st century examples.

Schools and other spaces

There is also a chapter on the acoustic design of schools, tracing the history of guidance and standards over the past 90 years, culminating in the 2015 edition of Building Bulletin 93. Several case studies are provided to illustrate techniques that have been used in schools to prevent or resolve particular acoustic problems.

A further chapter addresses the design of other types of space where the acoustic environment is important such as worship spaces, stations, open plan offices and museums. As before, the acoustic requirements and design principles are described and interesting examples given for each type of space.

The book concludes by speculating on possible implications of the coronavirus pandemic for

the future design of concert halls, theatres, schools and offices.

While strongly recommending this book, as a well-known pedant, I did spot a few typographical errors and inconsistencies in spellings. And I personally would prefer to see the reference lists at the end of each chapter presented in the standard alphabetical format.

Excellent introduction to the study of architectural acoustics

Nevertheless, I can thoroughly recommend this book to anyone interested in the acoustic design of spaces intended for speaking, listening and the performing arts. It would provide an excellent introduction to the study of architectural acoustics and should be added to student reading lists. It will also be of interest to more experienced practitioners and researchers since, as well as giving a historical perspective to the acoustic design of buildings, it describes many 21st century buildings, providing details of innovative designs and acoustic treatments. ☺

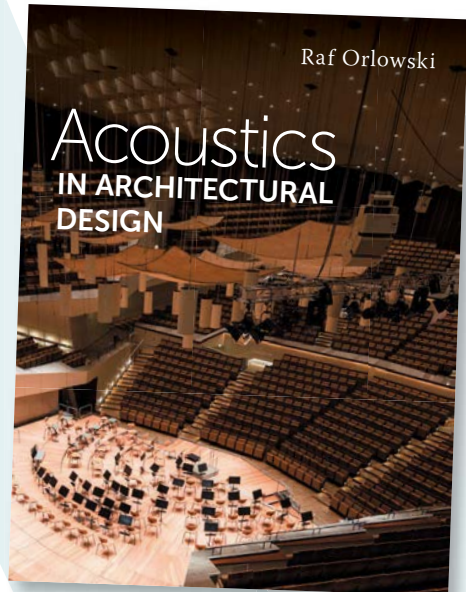

'Acoustics in Architectural Design' is available from Waterstones, Blackwells, Amazon, eBay, Browns Books and other leading bookshops. It's also available as a Kindle edition.

Institute Sponsor Members

Council of the Institute of Acoustics is pleased to acknowledge the valuable support of these organisations

Founding Key Sponsors



Acrefine Engineering Services Ltd	Couch Perry Wilkes Acoustics	Noise Solutions Ltd	Spectrum Acoustic Consultants
Advanced Noise Solutions Ltd	Direct Acoustic Solutions Ltd	noise.co.uk Ltd, The Haybarn	Stantec UK Limited
Aecom Infrastructure & Environment UK Ltd.	Echo Barrier Limited	Nova Acoustics Ltd	Waterman Infrastructure & Environment Limited
AMC Mecanocaucho	Emtec Products Ltd	Pliteq	WSP
ANV Measurement Systems	Farrat Isolevel Ltd	RBA Acoustics	Zenita Ceiling & Grid Solutions Limited
Apex Acoustics	Gracey & Associates	Rockfon	
Arup Acoustics	Hann Tucker Assoc	RSK Acoustics LTD	
Bickerdike Allen Partners	Hayes McKenzie Partnership Ltd	Saint-Gobain Construction Product UK	Applications for Sponsor Membership of the Institute should be sent to Membership at the Milton Keynes office. Details can be found on the IOA website.
Campbell Associates	Hilson Moran Partnership Ltd	t/a Saint-Gobain Ecophon	Members are reminded that ONLY Sponsor Members are entitled to use the Sponsor IOA logo in their publications, whether paper or electronic (including web pages).
Collecta Ltd	ISOMASS Ltd	Sandy Brown Ltd	
Christie & Grey Ltd	KP Acoustics Ltd	Sharps Redmore Partnership Ltd	
Clement Acoustics Ltd	Mason UK Ltd	Siderise Group,	
CMS Danskin Acoustics	Monarfloor Acoustic Systems Ltd	SITMA	
	National Physical Laboratory	Sound Reduction Systems Ltd	

Committee meetings 2022

DAY	DATE	TIME	MEETING
Thursday	3 February	11.00	Publications
Thursday	10 February	10.30	Meetings
Thursday	17 February	10.30	Membership
Thursday	24 February	10.30	Diploma Tutors and Examiners
Thursday	24 February	13.30	Education
Tuesday	1 March	10.30	Diploma Examiners (London)
Wednesday	2 March	10.30	Executive
Thursday	10 March	10.30	Executive
Wednesday	16 March	10.30	Council
Tuesday	22 March	11.00	CPD Committee
Tuesday	5 April	10.30	CCWPNA Examiners
Tuesday	5 April	13.30	CCWPNA Committee
Wednesday	6 April	10.30	Engineering
Thursday	7 April	10.30	Engineering
Thursday	21 April	10.30	Meetings
Thursday	5 May	11.00	Publications
Thursday	12 May	10.30	CCHAV Examiners
Thursday	12 May	13.30	CCHAV Committee
Wednesday	18 May	10.30	Executive
Thursday	19 May	10.30	Membership
Tuesday	24 May	10.30	Research Co-ordination (London)
Thursday	26 May	10.30	Executive
Wednesday	8 June	10.30	Council

Institute Council

Honorary Officers

President
S W Turner HonFIOA
ST Acoustics

President Elect
A Somerville HonFIOA

Immediate Past President
Prof B Gibbs FIOA
Liverpool University

Hon Secretary
F Rogerson MIOA
Arup Acoustics

Hon Treasurer
Dr M R Lester HonFIOA
Lester Acoustics LLP

Vice Presidents
J Hill MIOA
AAF Ltd
Dr P A Lepper MIOA
Loughborough University
G A Parry FIOA
ACCON UK

Ordinary Members

Dr C Barlow MIOA
Solent University
Dr B Fenech MIOA
Public Health England
D. Goodhand MIOA
Goodhand Acoustics
Dr K R Holland MIOA
ISVR
A Lamacraft MIOA
ACCON UK
Dr Y Liu FIOA
AECOM
R Mahtani MIOA
Sandy Brown Associates
Dr H S Sagoo MIOA
V L Wills MIOA
Atkins Acoustics

Chief Executive

A Chesney
Institute of Acoustics



Gracey & Associates

Setting Hire Standards ✓

We have been hiring sound and vibration measuring equipment to UK industry and businesses for almost 50 years.

We believe we enjoy a reputation for great service and we always strive to put our customers' needs first.

We stock an extensive range of equipment from manufacturers like: Bruel & Kjaer, Norsonic, Svantek, NTi, Vibrock, Davis, Casella and Larson Davis.

Our web-site offers a great deal of information, and our team are just one phone call away from helping you with your hire needs.

We look forward to hearing from you.

Contact us on 01234 708835 : hire@gracey.co.uk : www.gracey.co.uk

 **CAMPBELL ASSOCIATES**
SOUND, VIBRATION & AIR SOLUTIONS

**CADNA 2022
OUT NOW**

**THE COMPLETE SOFTWARE SUITE FOR
ACOUSTIC PROFESSIONALS**

Cadna  **R**[®]

Cadna  **A**[®]

Cadna  **B**[®]

t: 01371 871030 | e: hotline@campbell-associates.co.uk | w: campbell-associates.co.uk



Contact Support
Dedicated support gets you the help you need fast

- Available for purchase & hire
- A truly web-based solution
- No software required
- Fully certified and site proven hardware



New Features!

Just a few examples of the many features that have been recently introduced

AUDIO



- Triggered when individual limits are exceeded
- Separate audio-only trigger option available
- Audio-on-demand function for recalling any audio within the previous 24-hours
- Control .wav recording on the meter remotely



POWER

Monitor the power consumption and battery status of each position.

New PowerSave option:

- Units buffer and upload data once per hour
- Easy-to-use scheduler can be used to control when PowerSave is enabled
- Up to 50 hours with a single 12Ah battery and 2 weeks with a 100Ah battery
- Solar options available to power noise, vibration, weather and dust 24/7/365

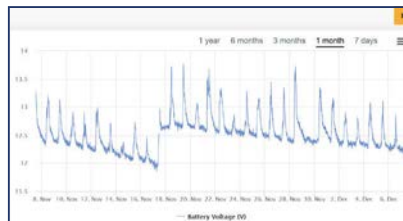

POLLUTION ROSES

- Daily, weekly and monthly pollution roses

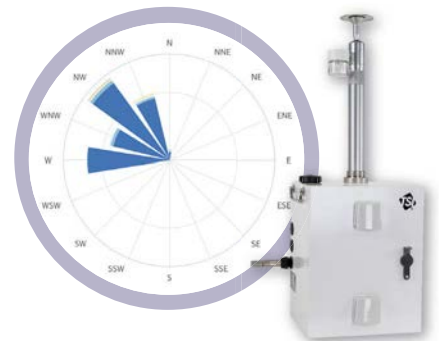

Existing customers Contact us now to begin enjoying these new features free of charge